



Moving Forward, Doing More

As you page through the 2012 Volume 1 catalog, you'll find a wide selection of American and European prototypes spread throughout the Premier O Scale product line as well as unique and varied RailKing locomotives, rolling stock and accessories. All are designed to appeal to as wide a cross range of O gauge and O scale enthusiasts as possible.

Every locomotive featured in the 2012 Volume 1 catalog now comes outfitted with Proto-Sound 3.0, the only onboard digital sound and control package that allows users to operate their locomotives in conventional or command mode using AC or DC power with command control protocol choices of DCS and DCC. Most of our Premier Line offerings are equipped with our unique Proto-Scale 3-2 feature which allows the locomotives to operate on 2 or 3-rail track with just a quick flip of a switch.



Proto-Sound 3.0 is our most advanced onboard locomotive digital package, first appearing in our HO lineup in 2006. With its 2011 debut in our O gauge products, we eliminated the onboard battery backup system found in Proto-Sound 2.0 locomotives without sacrificing locomotive performance. Proto-Sound 3.0 locomotives run exactly the same as their Proto-Sound 2.0 counterparts, will continue to play their shutdown sounds when power has been turned off in conventional mode, won't drop into neutral when traversing dirty track or switches and respond to all the same conventional and command control functions M.T.H. fans have become accustomed to over the years. This means you don't have to learn or purchase anything new to operate a Proto-Sound 3.0 equipped locomotive. The same AC or DC transformers you've been using to run your Ps2 locomotives will operate your new Ps3 locomotives and any DCS system purchased since 2002 when run as a Ps3 locomotive. Most importantly, you can run Ps3 locomotives along side Ps2 engines in lashups or by themselves. They all operate and perform the same!

Bigger Sound, No Batteries!

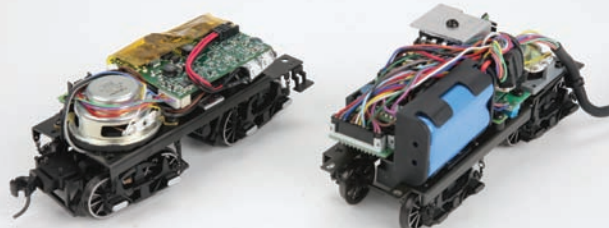

ProtoSound 3.0

ProtoSound 2.0

Proto-Sound 3.0 is more than just a new onboard package without a battery. It also brings a more powerful microprocessor and expanded onboard memory providing M.T.H. engineers with expanded capacity for features and improved digital sound sets. Its low voltage output capability has allowed us to replace all incandescent bulbs with long-lasting LED lighting effects and incorporate features like Rule 17 operating headlights that automatically dim whenever a locomotive enters neutral.

The 2012 Volume 1 catalog is also notable for what it doesn't feature. As each page is turned over, you will notice we haven't included any new steam locomotives in either the RailKing or Premier lineup.



No, we are NOT getting out of the steam locomotive manufacturing business!

Instead, we're taking a small break from new steam locomotive announcements so that we can work through the back orders for our 2011 cataloged steam locomotives. While we had hoped to incorporate production capacity improvements that would have allowed us to seamlessly "catch up" the schedule, delays in incorporating those changes has convinced us that we need to delay any new steam product announcements for a catalog or two.

In addition to a lack of new steam engine announcements in the 2012 Volume 1 catalog, you may have also noticed that we have not included the same variety of different freight car roadnames and paint schemes. While your choice of different freight car models in both the RailKing and Premier lineups remain unchanged from our last catalog, only two selections for each car type are presented in this new catalog. However, we'll be announcing at least two additional paint schemes for each car style via our electronic newsletters as the months pass.



As a reader of our catalog, you can stay abreast of these new announcements by subscribing to our electronic newsletter. Signing up is easy, just visit www.mthtrains.com. It's quick, it's easy and best of all, it's FREE.

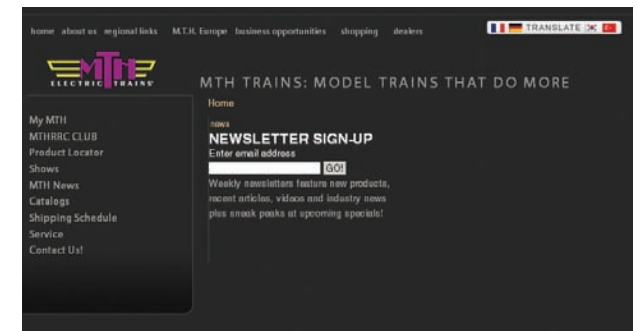

But why just read about new announcements when they're released? Why not help shape the M.T.H. product line with products you develop? That's right, we want our customers to help define what our future freight cars look like. We'll do this in a number of ways, including soliciting subscriber opinions on which roadname we should produce, creating contests for subscribers to actually design

new paint schemes and surveying modelers on what new cars we should tool up for. Naturally, we'll provide rewards to subscribers for participating in our "train-sourcing" events including free cars, discounts to our online store and much more.

At M.T.H. Electric Trains we've long relied on consumer input to help shape and guide our product line growth. Now, for the first time, we're letting our customers directly impact our future releases. This is your chance to have a real say in what your favorite model train manufacturer produces. Welcome aboard, it's great to have you here!

Introducing our second "3in3" hobby promotion

To understand the magnetism of model railroading, you've got to feel it with your own hands. That's what our new program, "See It, Hold It, Run It!" is about — giving potential hobbyists a hands-on experience in the hope of drawing them into our hobby.

In our recent O gauge catalogs, we've launched a program called "3in3," in which we're asking each model railroader to get three new people into our hobby over the next three years. As our first 3in3 promotion, we began the annual Blue Comet Award for the person or organization that does the most to promote the O gauge hobby to the public. "See It, Hold It, Run It!" ("SHR") is our second 3in3 promotion and is open to all scales.

How the program works

- **Participating organizations** can be hobby shops, clubs with permanent or modular layouts, or organizations that setup temporary layouts (such as annual holiday displays).

Program Goals

- To give children and adults the opportunity to hold a model train in their hands and then run it on an actual layout
- To create an online database of places and dates where folks can take advantage of that opportunity
- To give model railroad clubs a fundraising opportunity, by allowing them to purchase a "See It, Hold It, Run It!" HO or O gauge train set at dealer cost and raffle it off to the public (at the end of their open house or display period) as a fundraiser

- **A database on the MTH Website** will list the location of each SHR venue, dates and times, brief description of layout, and a contact person to schedule SHR sessions of about 15 minutes in length. Adults and children at least 7 or 8 years old (or younger if a participating organization permits) can sign up for an SHR session. Participating organizations can also do additional promotion of SHR sessions, which can be part of an open house, holiday display, or regular operating session.

- **MTH weekly emails** will promote upcoming SHR venues to our over-40,000 person subscriber list.

- **A "See It, Hold It, Run It!" session** will last about 15 minutes (at the organization's discretion) and consist of

- a) **See It:** brief introduction to the model (what scale it is, what kind of locomotive, what the model can do, for example)

- b) **Hold It:** having the child or adult hold the model in their hands and put it on the track

- c) **Run It:** explaining how the throttle and sounds work, and having the child or adult run the model around the display layout

- **A train set to be used for SHR sessions** can be purchased once per year at dealer cost by participating organizations that are not hobby shops. It is understood that club members will not want the general public handling delicate models, so participating organizations can purchase one Ready-to-Run MTH HO or 3-rail O gauge set per year to be used for SHR purposes and then be raffled off to benefit the organization. Organizations can choose from HO sets that are compatible with analog and DCC control, and O gauge sets with Proto-Sound 2.0 or 3.0.

- **MTH Ready-to-Run Catalogs** can be requested by participating organizations to be used as free handouts and to help promote their train set raffle.

For additional information and for assistance in taking advantage of this program, organizations and hobby shops are urged to contact MTH at SHRprogram@mth-railking.com

Contents

Proto-Sound 3.0	4
DCS	6
RailKing	8
Diesel	10
Transit	22
Freight Cars	24
Passenger Cars.....	36
Premier	38
Diesel	40
Rolling Stock.....	60
Freight Sets.....	74
Passenger Cars.....	80
European	82
Transformers	108
ScaleTrax	110
RealTrax	116
Couplers	120
Accessories	121
MTH RailRoaders Club	126
MTH Online	128

www.mthtrains.com

Follow Us Online



Benefits

From Other M.T.H. Product Lines



Even if you're not interested in Tinplate, One Gauge, or HO scale, our products in these other areas have benefits for you — because new features developed for other scales or gauges may eventually appear in Premier and RailKing O gauge trains.

Our One Gauge Triplex, for example, is North America's first production model with a smoking whistle — a feature we're currently developing for O gauge steamers.

Our Proto-Sound 3.0 HO engines have smaller electronics compatible with both our DCS system and the DCC command control system popular with 2-rail modelers around the globe. Our HO diesels have operating, scale proportioned Proto-Couplers that — like their O Gauge brethren — can be triggered anywhere on the layout.

Unlike most other model train companies, we have a Research & Development team — located in its own facility in Michigan — that benefits hobbyists across a wide range of interests and scales.



About Our Product Lines



In this catalog you'll find two of the five M.T.H. product lines, our O Gauge Premier and RailKing lines. While they differ in detail level and price, under the shell they're very much the same. Every engine in this catalog shares the same Proto-Sound 2.0 or later electronics and the same quality M.T.H. construction. Premier and RailKing O Gauge engines can be run together on your railroad in conventional or DCS command mode.

Premier engines are full O scale models, 1/48 the size of their prototypes. Because of this, they often require larger radius curves than comparable RailKing models. Premier engines are as detailed as we can reasonably make them, and feature a large number of added-on parts. On Premier steamers, for example, most piping is separately applied, whereas piping on RailKing steam engines is cast onto the boiler. While smoke is standard on virtually all M.T.H. steamers, only Premier and RailKing Scale and Imperial diesels feature smoke. Premier engines also have more elaborate lighting effects.

RailKing models have less detail and are lower priced than their Premier counterparts. Unless otherwise noted, all RailKing engines will negotiate O-31 curves. While RailKing Scale engines are full O scale size, other RailKing engines may have smaller proportions than their prototypes, to make them appropriate for smaller traditional layouts with O-31 curves. RailKing Imperial models are our top-of-the-line RailKing engines, with features such as real coal loads and separately illuminated marker lamps.

RailKing One Gauge equipment offers long-lasting, impact-resistant polycarbonate bodies, powerful flywheel-equipped DC can motors, and precise 1:32 scale proportions and detail. Features include metal handrails, spinning fans, constant voltage lighting, puffing smoke timed to the engine's chuffing, firebox glow, cab figures, sliding cab windows, and much, much more. In addition to the eye-popping detail, the line is built tough for years of outdoor operation.

Lionel Corporation Tinplate models are made of stamped tinplate or die-cast metal, generally boasting bright, colorful enamel paint and M.T.H.'s state-of-the-art digital electronics. Unlike Premier and RailKing models, these are not meant to be accurate reproductions of real trains. They provide collectors who cannot afford a pre-World War II original access to faithful, high quality, and highly detailed reproductions of model railroading's most nostalgic era.

The **M.T.H. HO** product line is our newest venture, with locomotives sporting the absolute latest in cutting-edge digital electronics for the HO market.



Celebrate Lionel Corporation Tinplate!

Modelers in other scales can celebrate Lionel Corporation Tinplate, the newest M.T.H. product line, with these HO and One Gauge freight cars. The new HO Operating Action Car was inspired by Lionel's 1950s aquarium car and features moving, backlit images of classic tinplate trains.



Proto-Sound

The Richest Set of Features in Model Railroading

Whether you operate with a conventional transformer or in command mode with DCC or DCS™ (M.T.H.'s Digital Command System), the Proto-Sound 2.0 or 3.0 system found in every locomotive in this catalog offers more realism, more fun, and more variety than any other locomotive control system in any scale.

VIVID ENGINE SOUNDS

Proto-Sound features digital recordings with CD-quality playback. We strive to make our sounds as authentic as possible, using the characteristic whistle for a particular steam engine, for example. With the optional DCS system, you can tune each engine to your preference by individually adjusting bell, horn or whistle, and chuff volume.

STATION SOUNDS

Proto-Sound passenger engines offer Passenger Station Proto-Effects™, a complete arrival and departure sequence that you can activate from your DCC or DCS controller. In most cases, the station sequence features an actual name train pulled by that particular engine. Freight engines include Freight Yard Proto-Effects, a symphony of freight terminal sounds.

ATMOSPHERIC SOUNDS

Crew conversations, the whoosh of a steam engine opening its cylinder cocks, and a host of other atmospheric sounds play automatically at random when using a conventional transformer — or can be activated manually from a DCC controller or the DCS handheld.

EXTRAORDINARY SLOW SPEED CAPABILITY

Proto-Sound engines can throttle down as slow as three scale miles per hour, highball down the main line, and maintain any speed in between. With certain DCC controllers, and any DCS controller, you can set engine speed in one-scale-mile-per-hour increments up to 120 smph. Go ahead, get out your stop watch and ruler and see how accurate our scale speeds are.

UNMATCHED SPEED CONTROL

The Proto-Speed Control™ built into Proto-Sound 3.0 acts like the cruise control on a car, keeping your train moving at the speed you select, regardless of hills and curves. You can even switch off the speed control if you prefer.

LIGHTING EFFECTS

Proto-Sound locomotives feature prototypical Rule 17 lighting, including a variety of realistic lighting effects.

GREAT SMOKE

Proto-Sound engines feature fan-driven ProtoSmoke™, the most powerful smoke system in the hobby. You can vary the intensity with the smoke "volume" control on the locomotive or remotely with any DCC or DCS controller.

SYNCHRONIZED CHUFF AND PUFF

Like a real steam engine, M.T.H. steamers feature puffs of smoke and steam chuff sounds synchronized with the drive wheels. Better than any other



Depending on the locomotive, these may include constant-brightness headlights, illuminated number boards, lighted marker lamps, and alternating ditch lights. In DCS operation, many of these lighting effects can be individually controlled.

MULTIPLE UNIT CAPABILITY

In DCS command mode, all locomotives set to the same speed — 37 scale miles per hour, for example — will move at virtually the same speed. This makes it easy to double or even triple-head nearly any combination of Proto-Sound 2.0 and 3.0 locomotives.

model train, an M.T.H. locomotive portrays the drama of a steam engine slowly chuffing and puffing as it pulls out of a station and gets up to speed.

BRAKE SOUNDS

Engine brakes squeal whenever you throttle back sharply or pull into a station. In DCS mode, you can trigger the brake sound with the Brake button on the DCS handheld.

FULL COMPATIBILITY WITH ALL OPERATING SYSTEMS

Right out of the box, every Proto-Sound 3.0 M.T.H. engine is compatible with all operating systems: conventional AC or DC, DCC, and our own Digital Command System (DCS). No switches to flip or adjustments to make. Your Proto-Sound engine senses what kind of power is on the rails; just set it on the track and run it.

BI-DIRECTIONAL COMMUNICATION

Proto-Sound 2.0 and 3.0 engines not only receive commands from the DCS system, they can report back vital information,

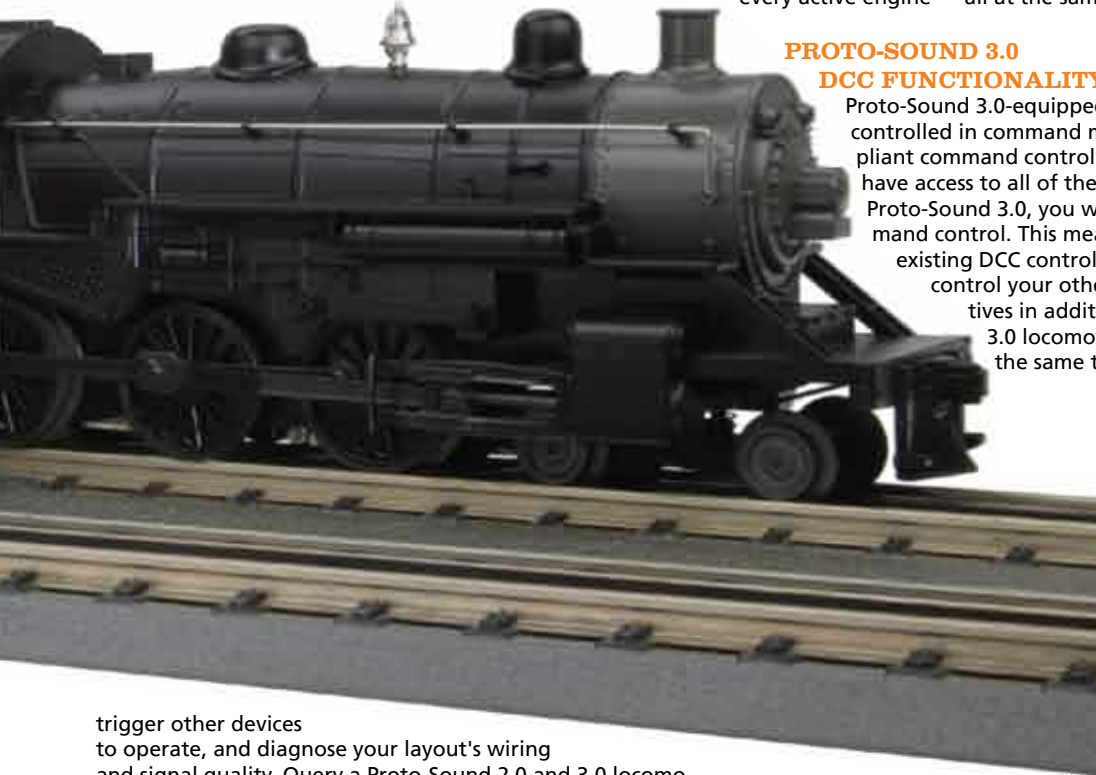

trigger other devices to operate, and diagnose your layout's wiring and signal quality. Query a Proto-Sound 2.0 and 3.0 locomotive to find out how many scale miles it's run or how many hours it's been powered up. Check out the strength of the DCS signal on the track or measure the track voltage at a trouble spot. Measure the length of your track in scale miles. All of this is possible today, but only with a Proto-Sound 2.0

and 3.0-equipped locomotive when operated using the DCS Digital Command System.

OPERATE 'EM ALL

In DCS command mode, unlike any other command system available today, you'll have one-touch control over every Proto-Sound 2.0 and 3.0-equipped locomotive at the same time. Imagine, with the ALL command, your DCS system will start-up every locomotive at the same time! Almost every DCS feature can be sent to all the active engines at once. Tell 'em to run at 10 scale miles per hour and they'll all start moving at the same time and at the same speed. Blow all their whistles at once, turn on or off their smoke, stop and reverse every active engine — all at the same time.

PROTO-SOUND 3.0 DCC FUNCTIONALITY

Proto-Sound 3.0-equipped locomotives can be controlled in command mode with any DCC-compliant command control system. While you won't have access to all of the incredible features of Proto-Sound 3.0, you will have full DCC command control. This means you can use your existing DCC controller to independently control your other DCC-equipped locomotives in addition to your Proto-Sound 3.0 locomotives on the same track at the same time.

Proto-Sound 3.0 DCC Features

When using a DCC controller, the following Proto-Sound 3.0 locomotive features are accessible:

Steam Features

- Headlight on/off
- Bell on/off
- Whistle/Horn on/off
- Start-up/Shut-down
- PFA initiate and advance
- Cab Light on/off
- Engine Sounds on/off
- Volume low, med, high, off
- Smoke on/off
- Forward Signal Sound
- Reverse Signal Sound
- Coupler Slack Sound
- Grade Crossing
- One-Shot Doppler on/off
- Extended Start Up
- Extended Shut Down
- Labor Chuff
- Drift Chuff
- Smoke Volume
- Single short whistle toot
- Coupler Close
- Feature Reset
- Idle Sequence 1
- Idle Sequence 2
- Idle Sequence 3
- Idle Sequence 4
- Brakes auto/off
- Cab Chatter auto/off
- Clickety-Clack auto/off

Diesel Features

- Headlight
- Bell
- Whistle/Horn
- Start Up/Shut Down
- Rear Coupler
- Front Coupler
- Engine Sounds On/Off
- Sound Volume
- Ditch Lights Auto/On/Off
- Forward Signal
- Reverse Signal
- Grade Crossing Signal
- Cab Light On/Off
- Extended Start Up
- Extended Shut Down
- Rev Up
- Rev Down
- Coupler Slack Sound
- Coupler Close
- One-Shot Doppler
- Feature Reset
- Idle Sequence 1
- Idle Sequence 2
- Idle Sequence 3
- Ditch Lights Auto/On/Off
- Brakes Auto/Off
- Cab Chatter Auto/Off
- Clickety-Clack Auto/Off
- Coupler Slack Sound

* Check your DCC Controller's manual to see how many features it can access.



Simply to Run

This remote is **SIMPLE**.

It speaks **ENGLISH, NOT ICONS**.

It can be **OPERATED EASILY WITH ONE HAND**.

It can be **UPGRADED FOR FREE** over the Internet.



It can run over 1300* Proto-Sound® 2.0 & 3.0 engines and every Lionel®, Atlas, Weaver, and Third Rail TMCC®, EOB, or Legacy™ engine ever made — and run 99 of them at the same time, on the same track, independently, in command mode.

It can also **RUN ALL CONVENTIONAL AC LOCOMOTIVES** without the purchase of any additional hardware.

With the addition of an Accessory Interface Unit (AIU), it can **OPERATE ANY O SCALE ACCESSORY OR SWITCH**. It can create scenes and routes that are triggered with one push of a button.

WHAT CAN YOUR REMOTE DO?

* Number of different Proto-Sound® 2.0 and 3.0 engines cataloged through the 2011 Volume 1 Catalog.

While all Lionel TMCC features can be accessed by the DCS handheld remote, at present some Legacy features cannot be accessed by the DCS remote.

Remote Shown Actual Size

the Best Way a Railroad

Command Control Explained

In conventional operation, an AC or DC transformer varies track voltage to adjust engine speed and direction. Command systems such as DCS, however, put a constant voltage on the track (around 18 volts for DCS) and vary speed by telling each engine how much of that voltage to use. Command control allows different engines to do different things — like run at different speeds, go in different directions, or make different sounds — even when they are on the same track.

In the DCS system, commands such as speed, direction, and sound control are sent as radio signals from the handheld throttle to a TIU (track interface unit). The TIU translates those radio signals into digital information that is sent through the rails and picked up by a receiver in the appropriate engine — telling it to go, for example, 37 miles per hour, blow the whistle, smoke more heavily, or any other command. DCS locomotives can also send information back to the handheld to let the operator know what they're doing.

Learn More About It



TRY IT at your local DCS Demo Center

Request a Complimentary DVD on DCS and M.T.H. technology. Log on to the DCS Web site, www.protosound2.com

Take your favorite Proto-Sound 2.0 or 3.0 engine to any DCS Demo Center and experience the additional features your engine has with DCS control. To find your nearest demo center or request your complimentary DVD, visit www.mthtrains.com.

DCS COMMANDER: Get into DCS on a budget

Ideal for small layouts running two or three Proto-Sound 2.0 locomotives**. Learn more about it in the 2010 RailKing Train Set catalog — or use our online Product Search feature to see more information and read the instruction manual.



DCS Commander System w/100 Watt Power Supply
50-1029 \$229.95

DCS Commander Controller (with out power supply)
50-1028 \$149.95



DCS Remote Commander Set
50-1033 \$39.95

**Requires Proto-Sound 2.0 locomotives with onboard 3-volt system, which can be identified by their square battery-charging jack; see the operator's manual for exact jack location.



DCS Remote Control System
50-1001 \$299.95



DCS Remote Control Handheld Unit
50-1002 \$149.95



DCS Track Interface Unit (TIU)
50-1003 \$179.95



DCS Accessory Interface Unit (AIU)
50-1004 \$99.95



Proto-Sound 2.0 Battery Charger
50-1019 \$14.95



6' Mini-to-Mini Cable
50-1009 \$9.95



Proto-Sound Battery
50-1008 \$11.95



TIU/TMCC-Legacy 6' Connector Cable
50-1032 \$19.95



AA NiCad Proto-Sound Battery
50-1024 \$11.95

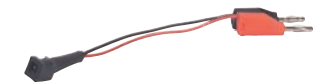

TIU/Barrel Jack Adapter Cable
50-1017 \$9.95



DCS Companion
60-1279
Digital Version \$12.95
Soft Cover \$29.95

Order from shopmthtrains.com

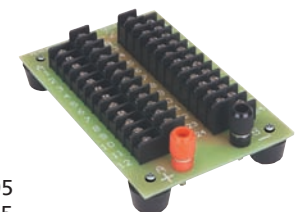

24-Port Terminal Block
50-1020 \$29.95
12-Port Terminal Block
50-1014 \$19.95

RailKing Intro

The Best Value in O-Gauge



Features typically found on RailKing models include:

- Durably constructed ABS diesel locomotive and car bodies
- Die-Cast metal steam locomotive boilers
- All-metal diesel and steam locomotive chassis
- All-metal wheels, gears and axles
- All-metal couplers
- All-metal freight and passenger car trucks w/ operating couplers
- Precision flywheel-equipped motors
- Synchronized Puffing Proto-Smoke™-equipped steam locomotives



First appearing in 1995 and now encompassing more than 7,800 items, RailKing is M.T.H.'s best-selling and most attractively priced product line. Cars and locomotives featured in the M.T.H. RailKing line are equipped with moderate detail and run on the same O gauge track as the intricately detailed O scale models found in our Premier Line. But, because RailKing models are shorter in length, they can negotiate tighter curves. In fact, most RailKing models can negotiate a circle as small as 31 inches in diameter, and some can operate on curves even smaller than that. This is a real advantage for model train enthusiasts with modestly sized layouts.

Over the years, the RailKing line has evolved into three subcategories: RailKing, RailKing Scale, and RailKing Imperial.





Features typically found on RailKing Scale models include all of our RailKing features, plus:

- Full 1/48 O scale proportions
- Additional grab iron detail
- Authentic, legible builder's plates
- Cab interior lighting
- Locomotive engineer figures
- Diesel cab interior detail
- Operating diesel smoke on larger models



RailKing Scale diesels are full scale-proportioned models featuring a higher level of detail than that found on regular RailKing models. Because of their scale proportions, RailKing Scale models require a minimum of O-31 curves in order to operate.

While RailKing Scale models are not as intricately detailed as their Premier counterparts, they mix well with any O scale 3-rail models, regardless of manufacturer. RailKing Scale diesels are an attractively priced alternative for modelers who want to operate full 1/48 scale O gauge trains.



Features typically found on Imperial models include all of our RailKing features, plus:

- Separate marker light housings with individual LED illumination
- Additional grab iron detail
- Authentic, legible builder's plates
- Cab interior lights
- Painted steam locomotive backhead gauges
- Safety chains for tender trucks
- Real tender coal loads



Most RailKing Imperial locomotives retain traditional proportions and O-31 minimum curve operation like regular RailKing locomotives, but are equipped with a level of detail usually found only on more expensive, full-scale engines that require much larger curves.

GP-20

diesel



RAILKING
scale

Features

- Metal Wheels, Axles and Gears
- Die-Cast Truck Sides, Pilots and Fuel Tank
- Colorful Paint Scheme
- Metal Chassis
- Metal Handrails and Decorative Horn
- Intricately Detailed ABS Body
- Locomotive Speed Control
- (2) Precision Flywheel Equipped Motors
- (2) Remotely Controlled Proto-Couplers™
- (1) Engineer Cab Figure
- Operating Smoke Unit
- Directionally Controlled Headlights
- Proto-Sound 3.0 With The Digital Command System
Featuring: Freight Yard Proto-Effects
- Unit Measures: 14 7/8" x 2 3/4" x 4"
- Operates On O-31 Curves



In the late '50s, railroads were looking for units with high-horsepower output. General Electric and Alco obliged by releasing units with 2,400 and 2,500-h.p. capability. General Motor's Electro-Motive Division, at first, was reluctant to chime in. They figured that turbocharging their 567 engine would drive up maintenance costs, and that was to be avoided. Yet, in 1959, EMD outshopped the GP20, a 16-cylinder, 2,000-h.p. road switcher, with its turbocharged 567D2 engine.

Union Pacific fostered EMD's change of heart. For it was only after the road experimented with and found success with turbocharging EMD's 567 engine in the GP9s on their roster, that EMD recognized the engine's potential. GP20s, closely resembled earlier Geeps, such as the GP7, GP9 and GP18. The increased power made the difference. As a result of that power, one distinguishing feature of the GP20 from prior Geeps, was its short exhaust stack, located just aft of

the first fan behind the cab. These units were produced until 1962. These popular units come alive once again in the exciting RailKing Scale division in four exciting roadnames. Each locomotive is built to scale proportions and includes more detail than those in the regular RailKing product line.



United States Army - GP-20 Diesel

30-20092-1	Proto-Sound 3.0	\$299.95
30-20092-3	Non-Powered	\$159.95



Buffalo & Pittsburgh - GP-20 Diesel

30-20090-1	Proto-Sound 3.0	\$299.95
30-20090-3	Non-Powered	\$159.95



Boston & Maine - GP-20 Diesel

30-20089-1	Proto-Sound 3.0	\$299.95
30-20089-3	Non-Powered	\$159.95



New York Central - GP-20 Diesel

30-20091-1	Proto-Sound 3.0	\$299.95
30-20091-3	Non-Powered	\$159.95

FM Trainmaster

diesel



RAIL KING
scale

Features

- Directionally Controlled Headlights
- Metal Wheels, Axles and Gears
- Die-Cast Truck Sides, Pilots and Fuel Tank
- (2) Remotely Controlled Proto-Couplers®
- Colorful Paint Scheme
- Metal Chassis
- Metal Handrails and Decorative Horn
- (2) Precision Flywheel Equipped Motors
- Intricately Detailed ABS Body
- (2) Cab Figures
- Locomotive Speed Control In Scale MPH Increments
- Operating Smoke Unit
- Illuminated Number Boards
- Proto-Sound 3.0 With The Digital Command System
- Featuring: Freight Yard Proto-Effects
- Unit Measures: 17" x 2 5/8" x 3 7/8"
- Operates On O-31 Curves

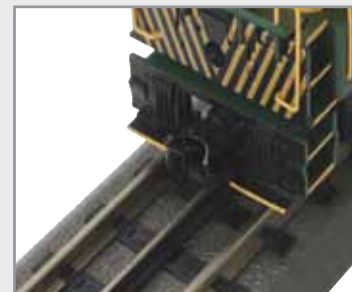

Fairbanks Morse got into the locomotive business because it made submarine engines. FM's unique opposed-piston diesel engine powered about half the U.S. Navy's World War II submarine fleet and developed a great reputation for reliability; the adaptation to railroad equipment during and after the war seemed like a natural transition.

In the opposed-piston motor, each cylinder had a piston at either end and the combustion chamber in the middle. There were no valves or cylinder heads. Intake and exhaust occurred through holes in the cylinder walls. The upper and lower banks of pistons each powered a separate crankshaft, and the two crankshafts were linked together to power the locomotive. While this sounds like a complex way to build an engine, the O.P. diesel in fact had several advantages over a conventional motor: less moving parts, terrific acceleration, and about double the horsepower per cylinder.

In 1953 the O.P. engine reached its zenith in the Trainmaster. Introduced at the Railroad Manufacturers' Supply Association show that year, FM's new locomotive took the show by storm. It was the most powerful single-motored diesel locomotive of its era and had a brawny body to match its bold name. Emblazoned in bright yellow and red, four Trainmaster demonstrators barnstormed the country and walked away with any consist the railroads threw at them. For one brief moment, Fairbanks Morse looked like a contender.

Ultimately, however, the opposed-piston engine proved ill-suited to locomotive use. The bone-jarring railroad environment was much rougher on the motor than a submarine cushioned by an ocean. The top crankshaft proved prone to oil leakage. Perhaps most important, maintenance was a nightmare. Whereas a single bad cylinder in an Electro-Motive diesel could be accessed by pulling off one cylinder head, a cylinder repair in an O.P. engine required removal of the top crankshaft and removal or disconnection of the entire top bank of cylinders - which also meant the roof of the locomotive had to come off. Ultimately, only 127 Trainmasters were sold to 11 U.S. and Canadian railroads.

In the world of O gauge railroading, however, the Trainmaster was a hit from the moment it went on the market in the mid-1950's. The engine's massive size and tremendous pulling power have made it one of the most-loved engines among 3-rail operators for nearly half a century. The Trainmaster returns to the RailKing Scale lineup in 2012 complete with the digital sound, amazing slow speed capability, and variable smoke output that make Proto-Sound 3.0 the best sound and control system in O gauge. Our model also features crew figures in the cab, LED illuminated number boards, headlights and illuminated front and rear marker lights.



Reading - FM Trainmaster Diesel

30-20093-1	Proto-Sound 3.0	\$299.95
30-20093-3	Non-Powered	\$159.95



Pennsylvania - FM Trainmaster Diesel

30-20094-1	Proto-Sound 3.0	\$299.95
30-20094-3	Non-Powered	\$159.95

**See Page 34 for
a Matching Caboose**



Milwaukee Road - FM Trainmaster Diesel

30-20095-1	Proto-Sound 3.0	\$299.95
30-20095-3	Non-Powered	\$159.95



Lackawanna - FM Trainmaster Diesel

30-20096-1	Proto-Sound 3.0	\$299.95
30-20096-3	Non-Powered	\$159.95

E-3 AA

diesel set



Features

- Metal Handrails
- Intricately Detailed ABS Bodies
- Directionally Controlled Headlights
- Metal Wheels, Axles and Gears
- Die-Cast Truck Sides, Pilots and Fuel Tank
- (2) Remotely Controlled Proto-Couplers®
- Colorful Paint Scheme
- Metal Chassis
- (2) Precision Flywheel Equipped Motors
- Locomotive Speed Control In Scale MPH Increments
- Proto-Sound 3.0 With The Digital Command System Featuring: Passenger Station Proto-Effects
- Unit Measures:
29 1/4" x 2 1/2" x 3 5/8"
- Operates On O-31 Curves



For many railfans, EMD's E-Series symbolizes all that was right about the golden age of passenger service. In the middle of the Great Depression, General Motors asked its Detroit stylists to design a sleek streamlined engine to head up consists of the lightweight passenger cars that had become fashionable. And because diesels did not have the pulling power of steam engines, these new units needed to be equipped to run in multi-unit lash-ups when more horsepower was needed to pull a long train. In addition to their modern appearance and multiple-unit capabilities, the E-series engines were also safer for the cab crew than the earlier box cabs, which put too little protection between the enginemen and any foreign object that might appear on the track.

Fully outfitted with the power and performance of Proto-Sound 3.0, these streamlined work-horses may just be the pride of your passenger based motive power. Marvel at sound and sights as these landmark engines streak by at the head of a glamorous passenger train in four colorful liveries.

Did You Know?

EMD's hugely successful and long-lived 567 engine was first used in the E-3. The 567 raised the engine's rating to 2000 horsepower instead of the 1800 horses that gave the original E-units their name, but the series kept the "E" designation as long as they were in production.



Chesapeake & Ohio - E-3 AA Diesel Engine Set
 30-20101-1 Proto-Sound 3.0 \$359.95
Chesapeake & Ohio - E-3 B Unit Diesel Engine
 30-20101-3 Non-Powered \$119.95



Chicago Northwestern - E-3 AA Diesel Engine Set
 30-20102-1 Proto-Sound 3.0 \$359.95
Chicago Northwestern - E-3 B Unit Diesel Engine
 30-20102-3 Non-Powered \$119.95

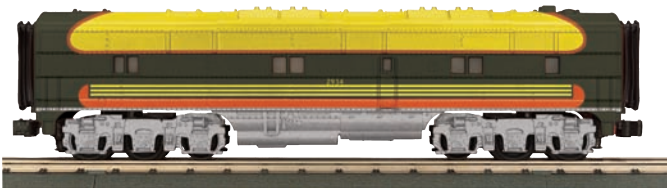

Seaboard - E-3 AA Diesel Engine Set
 30-20103-1 Proto-Sound 3.0 \$359.95
Seaboard - E-3 B Unit Diesel Engine
 30-20103-3 Non-Powered \$119.95



Southern - E-3 AA Diesel Engine Set
 30-20104-1 Proto-Sound 3.0 \$359.95
Southern - E-3 B Unit Diesel Engine
 30-20104-3 Non-Powered \$119.95



**Add Matching Passenger Cars
 (Pages 36-37)**

Alco Rs-1 diesel



RAILKING
scale

Features

- Intricately Detailed ABS Body
- Colorful Paint Scheme
- Metal Chassis
- Metal Handrails and Decorative Horn
- Die-Cast Truck Sides, Pilots and Fuel Tank
- (2) Cab Figures
- Directionally Controlled Headlights
- Metal Wheels, Axles and Gears
- (2) Remotely Controlled Proto-Couplers®
- (2) Precision Flywheel Equipped Motors
- Locomotive Speed Control In Scale MPH Increments
- Operating Smoke Unit
- Proto-Sound 3.0 With The Digital Command System Featuring: Passenger Station Proto-Effects
- Unit Measures: 14" x 2 1/2" x 4"
- Operates On O-31 Curves



The American Locomotive Company pioneered the multi-purpose "road switcher" design in 1941 with its 1000 hp RS-1. Alco's designers added a second, shorter hood to a basic switcher to make room for a steam boiler for passenger train heat. The short hood also afforded the crew additional accident protection. Smoother-riding trucks made the RS-1 suitable for the higher road speeds that would be daunting in a typical switcher. Although EMD's later GP7 and GP9 sold better and really established the road switcher as a universal locomotive, the RS-1 had the longest production run of any American-made diesel. The last new RS-1 left Alco's shops in 1960.

Interestingly, the first two years of RS-1 production went to the military. The 13 units that had been delivered to American railroads were requisitioned from their owners, and, along with 144 additional engines, were sent to Iran, Russia, and U.S. Army posts. These RS-1s were fitted with three-axle trucks to make them suitable for lighter rail on overseas roads. A group that plied the Trans-Iranian Railroad became known as "the diesels that saved Russia" because they brought in food and other supplies after the Luftwaffe had crippled Russian shipping. These engines later became the prototype for Russia's own early diesels.

Check out this model of America's first road switcher and we think you'll agree it offers Premier-level detailing at a RailKing price. Walkways have metal handrails and etched safety tread to prevent your 1/48-scale crewmen from slipping on a wet surface. End pilots have separately-added uncoupling levers. On the cab sides you'll find legible Alco builder's plates. Grab irons are separately added metal parts, as are the rooftop handles that allowed shop crews to remove roof panels for major repairs. Additional metal details include a horn, etched brass roof walkway, and a bell mounted under the frame.

Our RS-1 features dual pickup rollers on each truck, making this model nearly stall-proof on any three-rail O gauge switches. Throttle down as low as three scale miles per hour with a heavy freight or commuter train and maintain that speed as long as you wish, thanks to Proto-Speed Control. Listen to the authentic chant of a first-generation Alco 244 motor, rumbling with an offbeat gait that sounds like it could use a tune-up. While other manufacturers have offered the RS-1, no other O gauge model runs more smoothly or dependably, sounds as good, or is more fun to operate.



Long Island - Alco Rs-1 Diesel
30-20080-1 Proto-Sound 3.0 \$299.95

See Page 34 for a Matching Caboose



Ann Arbor - Alco Rs-1 Diesel
30-20081-1 Proto-Sound 3.0 \$299.95

See Page 34 for a Matching Caboose



Gulf Mobile & Ohio - Alco Rs-1 Diesel
30-20082-1 Proto-Sound 3.0 \$299.95

See Page 35 for a Matching Caboose

Northern Pacific - Alco Rs-1 Diesel
30-20083-1 Proto-Sound 3.0 \$299.95

SW-1 Switcher



Features

- Intricately Detailed ABS Body
- Colorful Paint Scheme
- Die-Cast Metal Chassis
- Directionally Controlled Headlight
- Metal Wheels, Axles and Gears
- Die-Cast Truck Sides, Pilots and Fuel Tank
- (2) Remotely Controlled Proto-Couplers@
- Metal Handrails and Decorative Horn
- (2) Precision Flywheel Equipped Motors
- Locomotive Speed Control In Scale MPH Increments
- Proto-Sound 3.0 With The Digital Command System
- Featuring: Freight Yard Proto-Effects
- Unit Measures: 12" x 2 3/4" x 4"
- Operates On O-27 Curves



The birth of the SW1 in January 1939 was a historic moment for the Electro-Motive Corporation. The tiny switcher ("S" for six hundred horsepower, "W" for welded frame) was EMC's first truly mass-produced loco, the first with Electro-Motive's own electrical gear, and the first mass-produced engine powered by the 567 diesel motor - which would become the backbone of first-generation American diesel power. Popular with railroads large and small, the SW1 stayed in production for 15 years, and many remained in service for three or more decades.

Our RailKing Scale SW1 offers Premier level details at a RailKing price. Separately added metal detail parts include front, side, and rear handrails; bell and horn; grab irons to allow access to the top of the hood; and handles for the sandbox lid on the front pilot (which doubled as a convenient seat for yard brakemen). Built to full 1/48 scale proportions, this model also offers authentic, legible EMD builder's plates and directionally operating front and rear headlights. Single or dual exhaust stacks, per individual prototypes, are also featured.

Our SW1 includes dual pickup rollers on each truck, making this model nearly stall-proof on any three-rail O gauge switches, despite its short wheelbase. Throttle down as low as three scale miles per hour to muscle a heavy cut of freight or passenger cars around your terminal - and maintain that speed as long as you wish, thanks to Proto-Speed Control and twin flywheel-equipped motors. Listen to the authentic chant of a first-generation EMD 567 motor. Pick up and drop off cars wherever you like, with remotely activated front and rear Proto-Couplers. Our full-scale, fully featured model of this tiny EMD workhorse offers everything you could want in a hard-working yard switcher.



Maryland & Pennsylvania - SW-1 Switcher Diesel

30-20097-1 Proto-Sound 3.0 \$299.95



SOO Line - SW-1 Switcher Diesel

30-20098-1 Proto-Sound 3.0 \$299.95

**See Page 34 for
a Matching Caboose**



Nickel Plate Road - SW-1 Switcher Diesel

30-20099-1 Proto-Sound 3.0 \$299.95



Baltimore & Ohio - SW-1 Switcher Diesel

30-20100-1 Proto-Sound 3.0 \$299.95

C30-7 diesel



RAILKING
scale

Features

- 1:48 Scale Proportions
- Directionally Controlled Headlights
- Intricately Detailed ABS Body
- Metal Wheels, Axles and Gears
- Die-Cast Truck Sides, Pilots and Fuel Tank
- (2) Remotely Controlled Proto-Couplers®
- Colorful Paint Scheme
- Metal Handrails and Decorative Horn
- (2) Precision Flywheel Equipped Motors
- Lighted Cab Interior
- Illuminated Number Boards
- (2) Engineer Cab Figures
- Operating Smoke Unit
- Locomotive Speed Control In Scale MPH Increments
- Proto-Sound 3.0 With The Digital Command System Featuring: Freight Yard Proto-Effects
- Unit Measures:
17 1/4" x 2 3/4" x 3 7/8"
- Operates On O-31 Curves



Debuting at the Chicago railroad industry equipment show in the fall of 1976, General Electric revealed the first of its Dash-7 line of locomotives, the C30-7. The locomotive was expected to replace the U30C, which at the time was GE's most successful six-axle model.

Utilizing numerous design changes, the external appearance of the C30-7 differed significantly from the U30C. The most obvious of these differences were the radiator "wings" located at the back of cab and a shortened hood. But each of these improvements came about as part of GE's desire to revolutionize their diesel offerings. Ultimately, their new locomotive succeeded by becoming a favorite of the major western haul hauling roads, the Santa Fe and the N&W.

Not since 2004 has the C30-7 been included in the M.T.H. product line but it returns in 2012 fully outfitted with the power and performance of Proto-Sound 3.0. Model railroaders looking for a value-rich road diesel need look no further than the C30-7. The patented Proto-Speed control system, digital sound variety of Proto-Sound 3.0 and awesome pulling power of two flywheel equipped motors will quickly endear this locomotive to its new owner.



Conrail - C30-7 Diesel

30-20084-1	Proto-Sound 3.0	\$319.95
30-20084-3	Non-Powered	\$159.95



CSX - C30-7 Diesel

30-20085-1	Proto-Sound 3.0	\$319.95
30-20085-3	Non-Powered	\$159.95



Norfolk & Southern - C30-7 Diesel

30-20086-1	Proto-Sound 3.0	\$319.95
30-20086-3	Non-Powered	\$159.95



Santa Fe - C30-7 Diesel

30-20087-1	Proto-Sound 3.0	\$319.95
30-20087-3	Non-Powered	\$159.95



Union Pacific - C30-7 Diesel

30-20088-1	Proto-Sound 3.0	\$319.95
30-20088-3	Non-Powered	\$159.95

R-36 Subway



Features

- Directionally Controlled Headlights
- Intricately Detailed ABS Bodies
- Metal Wheels, Gears and Axles
- (1) Remotely Controlled Proto-Coupler®
- Authentic Paint Scheme
- Illuminated Number Boards
- (2) Precision Flywheel Equipped Motors In Powered Unit
- Metal Chassis
- Die-Cast Truck Sides
- Lighted Detailed Interior
- Proto-Sound 3.0 With The Digital Command System Featuring: Station Stop Proto-Effects
- Unit Measures: 55" x 2 1/2" x 3 1/2"
- Operates On O-31 Track

New York City's R36 Subway cars were first constructed in 1964 by the St. Louis Car Company for the IRT division of the New York City subway system and are most famously remembered for their colorful World's Fair paint scheme that hauled visitors to the 1964 fair on IRT's Flushing Line. The 1964 fair marked the third time it was held in New York City and occupied nearly a square mile of land in Flushing Meadows Corona Park.

The World's Fair cars differed slightly from the R36 ML (for main line) cars with their distinct large picture windows. More common drop-sash side windows were found on both the R33ML and R36ML cars all of which ran for many years on the IRT main lines running on Broadway to Seventh Avenue as well as Lexington Avenue, mainly on the 1 and 3 trains. After completing overhauls in 1985, the R36 cars ran on the 6 train until about 2001 when they were replaced by the R142A cars.

With the arrival of the R142As on the 6 train, the R36MLs were transferred over to the 7 train before all but one pair

were eventually scrapped. That last pair, numbers 9542-9543, ran on the 7 until May 2003 before retiring in 2004 at the New York Transit Museum.

The RailKing R36 cars feature transit stop simulation available only from M.T.H. Designed specifically for our municipal transit cars, the unique Proto-Sound 3.0 transit program features Station Stop Proto-Effects, allowing you to program the train to stop automatically at designated station stops, even in Conventional Mode. When configured to run on automatic, the R36 stops itself at locations you define and calls out station names that you select in advance; the train essentially runs itself. And when you program the R36 for an out-and-back route, it even reverses itself and heads back downtown when it reaches the end of the line — stopping along the way at each station to broadcast the name of the stop and the hustle and bustle of passengers coming and going.

For more information on the R36 and the entire New York City transit system, visit www.nycsubway.org



Metropolitan Transportation - R-36 Subway

30-20105-1 Proto-Sound 3.0 \$429.95



RailKing Rolling Stock

High quality, traditionally sized RailKing Freight and Passenger Cars are fashioned from detailed bodies sporting colorful paint schemes that appeal to all levels of O Gauge railroading enthusiasts. An enormous variety of RailKing Freight Cars are available from which to choose, including many different car types and roadnames each mounted atop sprung-loaded, die-cast metal trucks with metal wheels, axles and operating metal couplers.

RailKing Passenger Cars are available in the popular 60' Streamlined and Madison style bodies. Configured in 4-car, 2-car and single-car configurations, each type features car interior detail, overhead interior lighting, end-of-car diaphragms and intricate under-car detail. All configurations are mounted atop die-cast metal 4 or 6-wheel trucks, each configured like our freight cars with operating metal couplers, metal wheels and metal axles.

Designed to bring authenticity and smooth performing operation to any O Gauge layout, modelers will find no finer O Gauge value than RailKing Freight and Passenger Cars. No matter what era or part of the country you are modeling, RailKing is sure to have something for you.



Learn about **NEW** Monthly Freight Car Announcements
Sign Up for Our **FREE** Newsletter

4-Bay Cylindrical Hopper

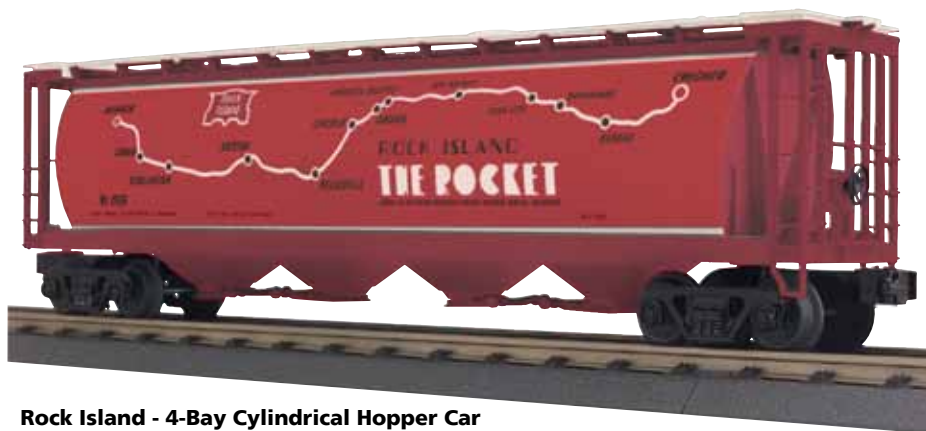

Rock Island - 4-Bay Cylindrical Hopper Car
30-75392 \$49.95



Union Pacific - 4-Bay Cylindrical Hopper Car
30-75393 \$49.95

Features

- Intricately Detailed Durable ABS Body
- Operating Die-Cast Metal Couplers
- Die-Cast 4-Wheel Trucks
- 4-Bay Hopper Measures: 10 7/8" x 2 3/8" x 3 7/8"
- Operates On O-27 Curves

Operating Hand Car



Christmas - Operating Hand Car
30-2573 \$59.95



Pennsylvania - Operating Hand Car
30-2574 \$59.95

**Handcars
Automatically
Reverse on Tracks
Equipped with
Bumpers**



M&M'S® Brand - Operating Hand Car
30-2597 \$69.95

©/™ M&M'S, the letter M and the M&M'S Characters are registered trademarks of Mars, Incorporated and its affiliates.
©MARS, Incorporated 2011



Features

- Intricately Detailed ABS Body
- Precision Motor
- (2) Moving Car Figures
- Automatic Bumper Reverse Mechanism (ABRM)
- Unit Measures: 4 3/8" x 1 15/16" x 2 15/16"
- Operates On O-27 Curves



Rounded Roof Box Car



Chesapeake and Ohio - Rounded Roof Box Car
30-74680 \$49.95



Norfolk Southern - Rounded Roof Box Car
30-74682 \$49.95

Ore Car



Chessie - Ore Car
30-75402 \$44.95



Northern Pacific - Ore Car
30-75405 \$44.95

Features

- Intricately Detailed Durable ABS Body
- Operating Die-Cast Metal Couplers
- Die-Cast 4-Wheel Trucks
- Box Car Measures: 11 5/8" x 2 1/2" x 3 7/16"
- Ore Car Measures: 7" x 2 1/2" x 3 1/8"
- Operates On O-27 Curves

Box Car



Toronto Hamilton & Buffalo - Box Car
30-74674 \$44.95



Milwaukee Road - Box Car
30-74672 \$44.95

50' Modern Box Car



Wisconsin Central - 50' Modern Box Car
30-74678 \$49.95

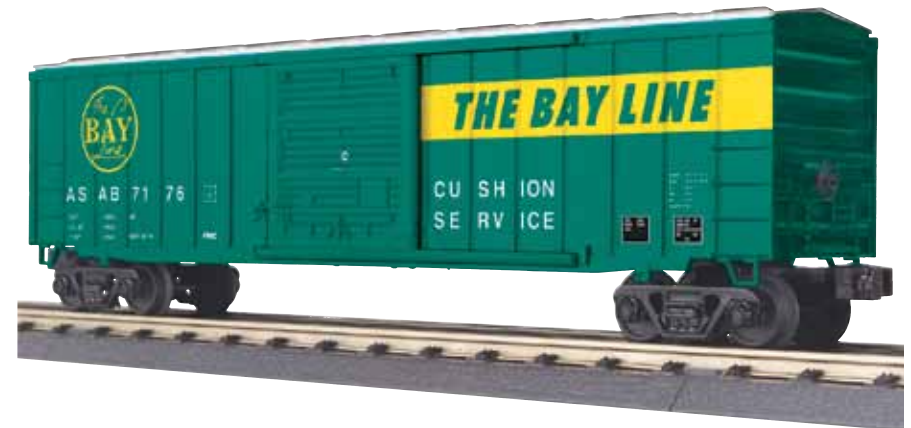

The Bay Line - 50' Modern Box Car
30-74677 \$49.95

Features

- Intricately Detailed Durable ABS Body
- Operating Die-Cast Metal Couplers
- Die-Cast 4-Wheel Trucks
- Box Car Measures: 11 1/2" x 2 3/8" x 2 5/16"
- Modern Box Car Measures: 12 7/8" x 2 9/16" x 3 9/16"
- Box Car Operates On O-27 Curves, Modern Box Car Operates on On O-31 Curves

Modern Tank Car



New Haven - Modern Tank Car
30-73369 \$49.95



New York Central - Modern Tank Car
30-73370 \$49.95

3-Dome Tank Car



AB - Anheuser Busch - 3-Dome Tank Car
30-73363 \$49.95

"© 2011 Anheuser-Busch, Inc. All Rights Reserved"



Norfolk Southern - 3-Dome Tank Car
30-73366 \$49.95

Features

- Intricately Detailed Durable ABS Body
- Operating Die-Cast Metal Couplers
- Die-Cast 4-Wheel Trucks
- Modern Tank Measures: 10 1/4" x 2 3/8" x 3 9/16"
- 3-Dome Tank Measures: 10 7/8" x 2 3/8" x 3 7/8"
- Operates On O-27 Curves

Gondola with Cover



CSX - Gondola with Cover
30-72087 \$49.95



Soo Line - Gondola with Cover
30-72089 \$49.95

Gondola with Crates



Chesapeake and Ohio - Gondola with Crates
30-72092 \$49.95



Southern - Gondola with Crates
30-72093 \$49.95

Features

- Intricately Detailed Durable ABS Body
- Operating Die-Cast Metal Couplers
- Die-Cast 4-Wheel Trucks
- Gondola Car Measures: 11 15/16" x 2 3/16" x 1 11/16"
- Operates On O-27 Curves

Flat Car with Bulkheads and Lumber



CN - Flat Car with Bulkheads and Lumber
30-76450 \$49.95



Milwaukee Road - Flat Car with Bulkheads and Lumber
30-76451 \$49.95

Flat Car with Bulkheads and Pipe Load



Norfolk Southern - Flat Car with Bulkheads and Pipe Load
30-76455 \$49.95



Union Pacific - Flat Car with Bulkheads and Pipe Load
30-76456 \$49.95

Features

- Intricately Detailed Durable ABS Body
- Operating Die-Cast Metal Couplers
- Die-Cast 4-Wheel Trucks
- Flat Car Measures: 11 5/8" x 2 1/4" x 3 3/4"
- Operates On O-31 Curves

Flat Car with Wheel Set



Alaska - Flat Car with Wheel Set
30-76460 \$49.95



Western Maryland - Flat Car with Wheel Set
30-76457 \$49.95

Flat Car with Trailer



SOO Line - Flat Car with Trailer
30-76446 \$49.95



Burlington - Flat Car with Trailer
30-76448 \$49.95

Features

- Intricately Detailed Durable ABS Body
- Operating Die-Cast Metal Couplers
- Die-Cast 4-Wheel Trucks
- Flat Car w/Wheel Set Measures: 11 5/8" x 2 1/2" x 3 7/16"
- Flat Car w/Trailer Measures: 11 5/8" x 2 1/4" x 1 7/16"
- Operates On O-27 Curves

4-Bay Hopper



Boston & Maine - 4-Bay Hopper Car
30-75394 \$44.95



Gulf Mobile & Ohio - 4-Bay Hopper Car
30-75395 \$44.95

Airslide Hopper



CSX - Airslide Hopper Car
30-75399 \$49.95



Chicago Northwestern - Airslide Hopper Car
30-75400 \$49.95

Features

- Intricately Detailed Durable ABS Body
- Operating Die-Cast Metal Couplers
- Die-Cast 4-Wheel Trucks
- 4-Bay Hopper Car Measures: 11 3/4" x 2 1/2" x 2 3/4"
- Airslide Hopper Car Measures: 11 5/8" x 2 1/4" x 3 3/4"
- Operates On O-27 Curves

American Crane Car and Tenders



Conrail - American Crane Car
30-79328 \$69.95



CP Rail - American Crane Car
30-79329 \$69.95



Conrail - Crane Tender Car
30-79332 \$49.95



CP Rail - Crane Tender Car
30-79333 \$49.95

Features

- Intricately Detailed Durable ABS Body
- Operating Die-Cast Metal Couplers
- Die-Cast 4-Wheel Trucks
- American Crane Measures: 17 5/8" x 2 5/8" x 4"
- Crane Tender Measures: 11 1/2" x 2 5/16" x 4"
- Operates On O-31 Curves

N5c Caboose



Long Island - N5c Caboose
30-77197 \$54.95



Pennsylvania - N5c Caboose
30-77198 \$54.95



United States Army - N5c Caboose
30-77200 \$54.95



SOO Line - N5c Caboose
30-77199 \$54.95

Features

- Intricately Detailed Durable ABS Body
- Operating Die-Cast Metal Couplers
- Die-Cast 4-Wheel Trucks
- N5c Caboose Measures: 9 1/8" x 2 5/8" x 4 1/4"
- Operates On O-27 Curves

Steel Caboose



Ann Arbor - Steel Caboose
30-77201 \$54.95



Boston & Maine - Steel Caboose
30-77202 \$54.95



Gulf Mobile & Ohio - Steel Caboose
30-77203 \$54.95



Western Maryland - Steel Caboose
30-77204 \$54.95

Features

- Intricately Detailed Durable ABS Body
- Operating Die-Cast Metal Couplers
- Die-Cast 4-Wheel Trucks
- Overhead Interior Lighting
- Steel Caboose Measures: 10 1/4" x 2 1/2" x 4 1/4"
- Operates On O-27 Curves



RailKing Passenger Cars



Long Island - 4-Car 60' Madison Passenger Set
30-69149 \$229.95



Long Island - 2-Car 60' Madison Combo/Diner Set
30-69150 \$119.95



Long Island - 60' Madison Coach Car
30-69151 \$59.95



Seaboard - 60' Streamlined ABS Coach Car
30-67677 \$59.95



Seaboard - 4-Car 60' Streamlined ABS Passenger Set
30-67675 \$229.95



Seaboard - 2-Car 60' Streamlined ABS Sleeper/Diner
30-67676 \$119.95



Seaboard - 60' Streamlined ABS Full-Length Vista Dome Car
30-67678 \$62.95



Southern - 4-Car 60' Streamlined ABS Passenger Set
30-67679 \$229.95



Southern - 2-Car 60' Streamlined ABS Sleeper/Diner
30-67680 \$119.95



Southern - 60' Streamlined ABS Coach Car
30-67681 \$59.95



Southern - 60' Streamlined ABS Full-Length Vista Dome Car
30-67682 \$62.95



Chicago Northwestern - 2-Car 60' Streamlined ABS Sleeper/Diner
30-67684 \$119.95



Chicago Northwestern - 4-Car 60' Streamlined ABS Passenger Set
30-67683 \$229.95



Chicago Northwestern - 60' Streamlined ABS Coach Car
30-67685 \$59.95



Chicago Northwestern - 60' Streamlined ABS Full-Length Vista Dome Car
30-67686 \$62.95



Chesapeake & Ohio - 60' Streamlined ABS Coach Car
30-67689 \$59.95



Chesapeake & Ohio - 4-Car 60' Streamlined ABS Passenger Set
30-67687 \$229.95



Chesapeake & Ohio - 2-Car 60' Streamlined ABS Sleeper/Diner
30-67688 \$119.95



Chesapeake & Ohio - 60' Streamlined ABS Full-Length Vista Dome Car
30-67690 \$62.95

Premier

O Scale model railroaders, whether they be 3-rail or 2-rail modelers, that have or plan to have a premier model railroad will find choosing an M.T.H. Premier Line locomotive or rolling stock item a worthy choice. Our steam, diesel and electric locomotives are unmatched in value and performance and our freight cars can withstand the scrutiny of many a seasoned modeler. Almost all of our Premier Line models can be configured for use on 2 or 3-rail track making M.T.H. Premier Line products the most versatile O scale products produced today.

Premier steam engines are the gold standard in O Scale railroading. These beautifully detailed 1:48 scale locomotives display the highest standards of craftsmanship, realistic detail, and solid construction. Each is configured with a smooth, powerful drive-train that performs like no other. Every Premier steamer features a die-cast boiler and tender, comes equipped with a flywheel-equipped motor, pours billowing smoke from the ProtoSmoke system prototypically timed with the drive wheels revolutions, and is outfitted with lighting effects that make for a realistic operating experience.

Many Premier diesels feature metal handrails and grill details and additional operating features such as moveable roof fans, operating marker lights, and illuminated number boards. Every one of our engines features a precisely designed body and a crisp, detailed paint scheme modeled closely to the original. This careful attention to detail does not stop with the appearance of the models. Each Premier locomotive features a world-class drive train capable of operating at incredibly slow speeds when run in command mode yet ensuring consistent performance when pulling long strings of cars.

Premier locomotives were introduced to fulfill the needs of established 3-rail model railroaders, operators, and collectors for whom accuracy, quality, and detail are essential. And while the authenticity of detail is designed to please the most discriminating of model railroaders, many Premier locomotives are now equipped with an industry-exclusive feature that allows our locomotives to run on 2-rail or 3-rail track.

Dubbed Proto-Scale 3-2, locomotives so equipped can be quickly configured for 2-rail or 3-rail operation by removing or adding the 3-rail pickups and flipping a power pickup switch to allow power to flow through one side of the locomotive's drive wheels or through the track's center rail. Because the onboard Proto-Sound 3.0 electronics can operate on AC or DC power and are equipped with both a DCC and a DCS receiver, operators now have an unprecedented number of ways to operate their locomotives. No other manufacturer today can match the number of operating modes as those found in an M.T.H. locomotive equipped with Proto-Sound 3.0.

Models equipped with Proto-Scale 3-2 are offered in two flavors, Hi-Rail Wheels or Scale Wheels. Operators planning on operating exclusively on a 2-rail empire, should select the latter while 3-rail operators will find the Hi-Rail Wheel versions to be their best option. 3-Rail Scale Operators whose layouts feature wide curves will also find the Scale Wheel models, especially diesel locomotives with their fixed pilots, to be worthy considerations.





Anatomy of a Premier Diesel Locomotive

Premier Line engines are full O scale models, 1/48 the size of their prototypes*. Because of this, they often require larger radius curves than comparable RailKing models. Premier engines, like the CSX Dash-8 shown here, are as detailed as we can reasonably make them, and feature a large number of added-on details. Premier engines also offer more elaborate lighting effects than RailKing models.

Look closely at any Premier Line model and you'll find a combination of superb detailing, prototype accuracy, rugged construction, and smooth, dependable operation that is unmatched by any other manufacturer.

*European models are scaled 1:43.5 or 1:45 depending on prototype



Detailed Metal Multi-Chime Horn

Sounds Recorded From an Actual U25B Diesel

See-Through Metal Grilles

Metal Handrails

Safety Tread on End Steps

All Wheels Powered

Etched Metal Safety Tread On Walkways

Fuel Tank Filler Pipe

Lighted Number Boards



Remotely activated Proto-Coupler on Hi-Rail Models



Sliding Cab Window



Single-Unit Powered Premier Diesels in Three Road Numbers*

Illuminated Number Boards

Crew Figures

Lighted Cab Interior

Windshield Wipers

Sand Filler Cap

Lighted Marker Lights

Safety Chain

Metal Handrails

Brake Cylinders and Air Brake Lines

Operates on 2- or 3-Rail Track, AC or DC Power

***Where Prototypical**

Directionally Controlled Headlights

All metal Wheels, axles and gears

Fixed Pilot on Scale Wheel Models

PROTO-SCALE™
32

Proto-Scale 3-2™

Operate on 3-Rail or 2-Rail Track with AC or DC Power!

Many Premier steam and diesel engines in this catalog are equipped with Proto-Scale 3-2, a unique M.T.H. feature that allows you to run the same engine on 2-rail or 3-rail track, under AC or DC power. Engines cataloged with hi-rail wheels are intended primarily for 3-rail operators, while engines with scale wheels are aimed at 2-rail DC operators as well as 3-rail AC operators looking for more scale realism. Scale-Wheeled versions of diesels have more-realistic fixed pilots, while Hi-Rail versions have swinging pilots to negotiate smaller-radius curves.

The conversion wheel kits listed on page 161 offer additional versatility. Each kit contains enough wheel sets for (2) power trucks. Scale wheels are polished, turned metal with scale treads and flange height, and are mounted on metal axles with one insulated side for use on 2-rail O Scale track systems. Two wheel sets in each kit contain a pre-mounted drive gear.

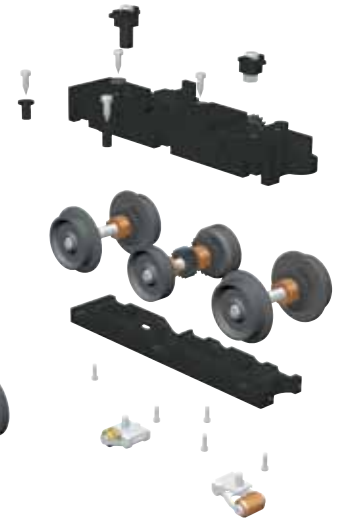

Easily Convertible from Hi-Rail to Scale Wheels OR Scale to Hi-Rail Wheels



Centipede AA

diesel set



Features

- 1:48 Scale Proportions
- Directionally Controlled Headlights
- Intricately Detailed ABS Bodies
- Metal Wheels, Axles and Gears
- Die-Cast Truck Sides, Pilots and Fuel Tank
- (2) Remotely Controlled Proto-Couplers®
- Metal Chassis
- (2) Precision Flywheel Equipped Motors In Each A Unit
- Locomotive Speed Control In Scale MPH Increments
- Lighted Cab Interiors
- Illuminated Number Boards
- Lighted Marker Lights
- (2) Engineer Cab Figures In Each A Unit
- Moveable Roof Fan Blades
- Metal Body Side Grilles
- (2) Operating Smoke Units
- Proto-Sound 3.0 With The Digital Command System Featuring: Freight Yard Proto-Effects
- Unit Measures: 46" x 2 1/2" x 3 3/4"
- Operates On O-72 Curves

No one who has ever seen a profile of the Centipede cannot doubt where the engine got its nickname. With 12 axles under each A unit, the enormous Baldwin-built engine is easy to identify. Seaboard Air Line took delivery of its first Centipede, #4500, in 1945. This fast and powerful engine allowed SAL with its twisting, curving lines to compete with its local rival, Atlantic Coast Line, which had far flatter and straighter track to maneuver. Although SAL's Centipedes were bought primarily to head up heavy, fast freight runs speeding fresh Florida produce to northern markets, they were sometimes pressed into passenger service. Maintenance - especially of each unit's 96 brake shoes

and 40 brake cylinders - proved too expensive to continue for long, and the Centipedes were retired in 1957, after having been assigned to service in Florida for their last few years.

Did You Know:

The Union Pacific assigned roadnumbers to their Centipede engines but then abruptly cancelled their order at the last minute. Baldwin then used those engines in their demonstrator paint scheme, taking the engine on the road to solicit other railroad's interest.



Pennsylvania - Centipede AA Diesel w/ Proto-Sound 3.0

20-20230-1 \$799.95



Pennsylvania - Centipede AA Diesel w/ Proto-Sound 3.0

20-20231-1 \$799.95

GP38-2 diesel



Features

- (2) Remotely Controlled Proto-Couplers®
- Metal Chassis
- (2) Precision Flywheel Equipped Motors
- Illuminated Number Boards
- Intricately Detailed ABS Body
- Directionally Controlled Headlights
- Die-Cast Truck Sides, Pilots and Fuel Tank
- Authentic Paint Scheme
- Metal Handrails and Decorative Horn
- Lighted Marker Lights
- (2) Engineer Cab Figures
- Moveable Roof Fan Blades
- Metal Body Side Grilles
- Operating Smoke Unit
- Metal Wheels, Axles and Gears
- Lighted Cab Interior
- Locomotive Speed Control In Scale MPH Increments
- Proto-Scale 3-2 3-Rail/2-Rail Conversion Capable
- 1:48 Scale Proportions
- Proto-Sound 3.0 With The Digital Command System Featuring: Freight Yard Proto-Effects
- Unit Measures: 15 1/2" x 2 3/4" x 4"
- High-Rail Wheels Operate On O-31 Curves
- Scale Wheels Operate on 31" Radius Curves



Produced from 1972 to 1986, the GP38-2 helped inaugurate Electro-Motive's "Dash-2" series of locomotives and became one of EMD's all-time best sellers. With over 2200 engines sold throughout North America, rare was the railroad that did not roster these reliable, second-generation EMD workhorses.

Building on the success of the GP38 introduced in 1966, the Dash-2 model looked almost identical on the outside but incorporated a host of internal upgrades that lowered exhaust emissions and improved reliability, ease of maintenance, and tractive effort. Most significant was the replacement of the maze of hard-wired circuits, switches, interlocks, and relays — which had characterized first-generation diesels and had been the source of many of their service issues — with modular, solid-state electronics. Other improvements toughened the pistons, rings, and bearings of the 2000-horsepower, non-turbocharged model 645 prime mover.

The result was an engine so hard working and dependable that it became as common on American railroads as the F-unit was in the 1950s and '60s. Trains magazine recognized this in 1982 by designating B&O GP38 (a pre-Dash-2 model) as the All American Diesel; the engine resides today in the Baltimore & Ohio Railroad Museum, repainted in its 1982 Chessie System colors. Many GP38-2s have soldiered on for more than three decades and remain in service today on short lines and regional railroads.

While our Premier model is not the only O gauge version of this second-generation stalwart, it offers the best combination of detail, realism, and performance of any 1/48 scale GP38-2. Added-on detail parts include windshield wipers, metal see-thru body grilles, lift rings, metal grab irons and handrails, and see-thru rooftop fan housings, as well as brake cylinders, air pipes, and swing hangers on our super-detailed Blomberg trucks. And in command mode with the DCS system, you can create a lashup combining one or more GP38-2s with other Proto-Sound 3.0 first- or second-generation power — and run them all from a single throttle just like the prototype.



New York & Atlantic - GP38-2 Diesel w/ Proto-Sound 3.0

20-20207-1	Hi-Rail Wheels	\$429.95
20-20207-2	Scale Wheels	\$449.95
20-20207-3	Non-Powered	\$199.95

Chicago & Northwestern - GP38-2 Diesel w/ Proto-Sound 3.0

20-20209-1	Hi-Rail Wheels	\$429.95
20-20209-2	Scale Wheels	\$449.95
20-20209-3	Non-Powered	\$199.95



Indiana Railway - GP38-2 Diesel w/ Proto-Sound 3.0

20-20224-1	Hi-Rail Wheels	\$429.95
20-20224-2	Scale Wheels	\$449.95
20-20224-3	Non-Powered	\$199.95



CSX - GP38-2 Diesel w/ Proto-Sound 3.0

20-20206-1	Hi-Rail Wheels	\$429.95
20-20206-2	Scale Wheels	\$449.95
20-20206-3	Non-Powered	\$199.95



BNSF - GP38-2 Diesel w/ Proto-Sound 3.0

20-20210-1	Hi-Rail Wheels	\$429.95
20-20210-2	Scale Wheels	\$449.95
20-20210-3	Non-Powered	\$199.95



Iowa Interstate - GP38-2 Diesel w/ Proto-Sound 3.0

20-20225-1	Hi-Rail Wheels	\$429.95
20-20225-2	Scale Wheels	\$449.95
20-20225-3	Non-Powered	\$199.95

SD70ACe

diesel



Features

- Intricately Detailed ABS Body
- Die-Cast Truck Sides, Pilots and Fuel Tank
- Colorful Paint Scheme
- Metal Chassis
- Metal Handrails and Decorative Horn
- (2) Cab Figures
- Moveable Roof Fan Blades
- Metal Body Side Grilles
- Directionally Controlled Headlights
- Metal Wheels, Axles and Gears
- (2) Remotely Controlled Proto-Couplers®
- (2) Precision Flywheel Equipped Motors
- Locomotive Speed Control In Scale MPH Increments
- Lighted Cab Interior
- Illuminated Number Boards
- Lighted Marker Lights
- Operating Ditch Lights
- Operating Smoke Unit
- Proto-Scale 3-2 3-Rail/2-Rail Conversion Capable
- 1:48 Scale Proportions
- Proto-Sound 3.0 With The Digital Command System Featuring: Freight Yard Proto-Effects
- Unit Measures: 18 1/2" x 2 5/8" x 4"
- High-Rail Wheels Operate on O-42 Curves
- Scale Wheels Operate on 42" Radius Curves



The SD70ACe is Electro-Motive Division's hope for the future. While designed to meet the Environmental Protection Agency's Tier-2 emissions requirements that took effect on January 1, 2005, this replacement for the SD70MAC also seems to have a higher purpose: to recapture the lead in North American locomotive sales that EMD lost to General Electric in 1987.

Under the hood beats a third-generation model 710 diesel with 4300 horsepower; only slight modifications were needed to make the model 710 meet new emission standards. With 5000 such motors in service worldwide and a reputation for dependability, EMD reasoned that shop crews would prefer familiar technology.

Other than the prime mover, however, virtually every element of the SD70ACe has been re-thought to create a 21st century locomotive. Ergonomics were a prime consideration. The engine's angular nose offers the crew far better visibility than most other locomotives, and the cab is comfortable for engineers of almost any size. Digital screens provide a range of information on what is happening both inside the locomotive and out on the road. The cab easily accommodates a crew of three - an important factor in a modern world without cabooses. And there is, of course, a cupholder for the engineer.

The SD70ACe also offers, in EMD's words, "outstanding improvements in maintainability." All electrical wires are on the right side of the locomotive and all piping is on the left, with most pipes and wires routed under the frame so they can be serviced by a man standing outside the engine - rather than crawling around at the bottom of the engine room. The number of electrical components has been drastically reduced while access to the remaining parts has been seriously improved. And the time between service intervals has been doubled, from every three months to every six months.

Did you know?

IntelliTrain, an option on the SD70ACe, uses cellular and GPS technology to allow a railroad's maintenance department to monitor operating conditions and problems as they occur out on the road - making diagnosis and repair considerably easier.



Union Pacific - SD70ACe Diesel w/ Proto-Sound 3.0

20-20219-1	Hi-Rail Wheels	\$449.95
20-20219-2	Scale Wheels	\$469.95
20-20219-3	Non-Powered	\$219.95



Denver Rio Grande - SD70ACe Diesel w/ Proto-Sound 3.0

20-20216-1	Hi-Rail Wheels	\$449.95
20-20216-2	Scale Wheels	\$469.95
20-20216-3	Non-Powered	\$219.95



Katy - SD70ACe Diesel w/ Proto-Sound 3.0

20-20217-1	Hi-Rail Wheels	\$449.95
20-20217-2	Scale Wheels	\$469.95
20-20217-3	Non-Powered	\$219.95



Norfolk Southern - SD70ACe Diesel w/ Proto-Sound 3.0

20-20218-1	Hi-Rail Wheels	\$449.95
20-20218-2	Scale Wheels	\$469.95
20-20218-3	Non-Powered	\$219.95



Caterpillar - SD70ACe Diesel w/ Proto-Sound 3.0

20-20215-1	Hi-Rail Wheels	\$449.95
20-20215-2	Scale Wheels	\$469.95
20-20215-3	Non-Powered	\$219.95



© 2011 Caterpillar
 CAT, CATERPILLAR, their respective logos, "Caterpillar Yellow" and the "Power Edge" trade dress, as well as corporate and product identity used herein, are trademarks of Caterpillar and may not be used without permission.
 www.cat.com
 M.T.H. Electric Trains, a licensee of Caterpillar Inc.

U25B diesel



Scale Wheeled Version
with Fixed Pilot Shown

Features

- Die-Cast Truck Sides, Pilots and Fuel Tank
- Intricately Detailed ABS Body
- Authentic Paint Scheme
- Metal Body Side Grilles
- Moveable Roof Fan Blades
- Metal Chassis
- Metal Handrails and Decorative Horn
- Directionally Controlled Headlights
- Metal Wheels, Axles and Gears
- (2) Remotely Controlled Proto-Couplers®
- (2) Precision Flywheel Equipped Motors
- Lighted Cab Interior
- Illuminated Number Boards
- Operating Smoke Unit
- (2) Engineer Cab Figures
- Locomotive Speed Control In Scale MPH Increments
- Proto-Scale 3-2 3-Rail/2-Rail Conversion Capable
- 1:48 Scale Proportions
- Proto-Sound 3.0 With The Digital Command System Featuring: Freight Yard Proto-Effects
- Unit Measures: 16" x 3 1/8" x 4"
- High-Rail Wheels Operate on O-42 Curves
- Scale Wheels Operate on 42" Radius Curves



By 1960, EMD — the Electro-Motive Division of General Motors — looked like the clear winner in the race to dieselize America. ALCo was running a distant second, Baldwin was gone, and Fairbanks-Morse was on life support. General Electric, having dissolved its partnership with ALCo in 1953, had seemingly settled into a secondary role as supplier of electrical gear to other manufacturers and builder of small export locomotives. What nobody realized was that GE had quietly been preparing a comeback of such epic proportions that in little more than two decades it would overtake EMD as America's number one locomotive builder — a lead that continues to this day. GE's comeback engine was the U25B.

The year after its breakup with ALCo, GE had begun testing an A-B-B-A diesel set on the Erie Railroad, powered by Cooper Bessemer prime movers; GE had purchased the rights to refine and develop the motors on its own. What the world assumed was an experimental export engine was in fact a rolling laboratory aimed at developing a heavy freight locomotive that would be more powerful, more reliable, and require less maintenance than the competition. When the U25B (Universal Series, 2500 horsepower, 4-wheel trucks) debuted in 1960, its turbocharged 4-cycle, 16-cylinder diesel outperformed its rivals by 100hp. More important, its modular electronics were more reliable than those of contemporary engines and, according to GE, used up to 60% fewer components. And while the louvered flanks of competitive diesels concealed numerous air filters that required frequent cleaning, the "U-Boat," as it came to be called, featured a central cooling air system with a self-cleaning filter. The carbody was pressurized to keep dirt out of the machinery, and the locomotive featured an advanced wheel-slip system. Together, these features helped define the second generation of diesel power, which would replace the F-units, Geeps, and other pioneering engines that were wearing out.

M.T.H. returns our superbly detailed model of America's first second-generation diesel. Per prototypes, our models will replicate both the "classic" U25B with its wide windshield and flat-top nose, and the later-production version with split windshield and sloping nose.



Chessie - U25B Diesel w/ Proto-Sound 3.0

20-20220-1	Hi-Rail Wheels	\$449.95
20-20220-2	Scale Wheels	\$469.95
20-20220-3	Non-Powered	\$199.95



Conrail - U25B Diesel w/ Proto-Sound 3.0

20-20221-1	Hi-Rail Wheels	\$449.95
20-20221-2	Scale Wheels	\$469.95
20-20221-3	Non-Powered	\$199.95



Norfolk & Western - U25B Diesel w/ Proto-Sound 3.0

20-20222-1	Hi-Rail Wheels	\$449.95
20-20222-2	Scale Wheels	\$469.95
20-20222-3	Non-Powered	\$199.95



Union Pacific - U25B Diesel w/ Proto-Sound 3.0

20-20223-1	Hi-Rail Wheels	\$449.95
20-20223-2	Scale Wheels	\$469.95
20-20223-3	Non-Powered	\$199.95

GP-9 diesel



Features

- Intricately Detailed ABS Body
- Die-Cast Truck Sides, Pilots and Fuel Tank
- Colorful Paint Scheme
- Metal Chassis
- Metal Handrails and Decorative Horn
- (2) Engineer Cab Figures
- Metal Body Side Grilles
- Operating Smoke Unit
- (2) Remotely Controlled Proto-Couplers®
- 1:48 Scale Proportions
- Metal Wheels, Axles and Gears
- (2) Precision Flywheel Equipped Motors
- Locomotive Speed Control In Scale MPH Increments
- Lighted Cab Interior
- Illuminated Number Boards
- Lighted Marker Lights
- Moveable Roof Fan Blades
- Proto-Sound 3.0 With The Digital Command System Featuring: Freight Yard Proto-Effects
- Unit Measures: 14 3/4" x 2 1/2" x 3 3/4"
- Operates On O-31 Curves



Electro-Motive Division's GP (for "General Purpose") engines were the brainchild of project engineer Dick Dilworth. In the late 1940s, Dilworth saw that America's 30,000 miles of main line rail had been virtually dieselized, but the 130,000 miles of secondary lines that carried half of the nation's freight traffic were still largely steam powered. He viewed that as a huge marketing opportunity.

In *The Dilworth Story*, a book published by Electro-Motive Division in 1954, Dilworth explained how he tried to meet that opportunity: "In planning the GP, I had two dreams. The first was to make a locomotive so ugly in appearance that no railroad would want it on the main line or anywhere near headquarters, but would keep it out as far as possible in the back country, where it could do really useful work. My second dream was to make it so simple in construction and so devoid of Christmas-tree ornaments and other whimsy that the price would be materially below our standard main-line freight locomotives."

Of course, Dilworth's explanation conveniently ignored the fact that Alco's arguably uglier RS-1 had introduced the road switcher concept eight years before EMD. And in one sense, Dilworth's project was a failure. Railroads bought Geeps for mainline service and relegated older power to secondary lines as they had always done. But his brainchild became the runaway best-seller among first-generation diesel power. U.S. and Canadian railroads bought nearly 7,000 copies of the 1500 horsepower GP7, introduced in 1949, and the 1750 horsepower GP9, produced from 1954 through 1963.

The GP9 returns to the Premier line with the full range of superb detailing you expect in a Premier locomotive: see-through end steps, body side grilles, and roof fan housings; metal side and end handrails; separate metal grab irons; metal lift rings on its roof panels; windshield wipers; and the super-detailed Blomberg trucks introduced earlier on our Premier F-units. Our Geeps also feature authentic first-generation diesel sounds including a single-chime air horn and the throb of an EMD 16-cylinder model 567 prime mover - so named because each of its cylinders displaced 567 cubic inches.



Reading - GP-9 Diesel w/ Proto-Sound 3.0

20-20202-1	Hi-Rail Wheels	\$429.95
20-20202-3	Non-Powered	\$199.95



Atlantic Coast Line - GP-9 Diesel w/ Proto-Sound 3.0

20-20203-1	Hi-Rail Wheels	\$429.95
20-20203-3	Non-Powered	\$199.95



Canadian Pacific - GP-9 Diesel w/ Proto-Sound 3.0

20-20204-1	Hi-Rail Wheels	\$429.95
20-20204-3	Non-Powered	\$199.95



Western Maryland - GP-9 Diesel w/ Proto-Sound 3.0

20-20205-1	Hi-Rail Wheels	\$429.95
20-20205-3	Non-Powered	\$199.95

RS-11 High-Hood diesel

Features

- Intricately Detailed ABS Body
- Die-Cast Truck Sides, Pilots and Fuel Tank
- Colorful Paint Scheme
- Metal Chassis
- Metal Handrails and Decorative Horn
- (2) Cab Figures
- Directionally Controlled Headlights
- Metal Wheels, Axles and Gears
- (2) Remotely Controlled Proto-Couplers™
- (2) Precision Flywheel Equipped Motors
- Locomotive Speed Control In Scale MPH Increments
- Proto-Scale 3-2 3-Rail/2-Rail Conversion Capable
- 1:48 Scale Proportions
- Operating Smoke Unit
- Proto-Sound® 3.0 With The Digital Command System Featuring Freight Yard Proto-Effects™
- Unit Measures: 14 7/8" x 2 1/2" x 4 1/16"
- Operates On O-31 Curves



The RS-11 was Alco's answer to the hugely popular Electro-Motive Geep. Alco had, after all, invented the road switcher: a multipurpose engine with great visibility fore and aft, capable of anything from slow-speed switching to full-throttle mainline hauling. And in the late 1940s and early '50s, Alco's pioneering RS-1 and RS-3 had sold well. But Alco's 1600 hp model 244 motor had acquired a reputation for unreliability, and the Electro-Motive GP7 and GP9, copying the road switcher concept, became the runaway best-sellers of first-generation diesels.

One wonders today if Alco's problem was really its motor or EMD's commanding sales lead. Back in World War II, EMD had been the only company permitted to manufacture road diesels, and shop crews nationwide had learned to service the EMD 567 prime mover. Perhaps a lack of familiarity led to lesser-quality maintenance of Alco motors; as evidence, Alco fans today point to the New Haven, an all-Alco railroad that got great service from its Alco fleet while others complained.

In any case, the RS-11 addressed the reliability issue with a new Model 251 V-12 motor, offering 50 more horsepower than the contemporary GP9. At least a dozen Class 1 railroads in the U.S., Canada, and Mexico bought the new engine after it was introduced in 1956. Some used it in passenger service with an optional train heat boiler. Later a low-nose version with better forward visibility was offered. But while the RS-11 was a good locomotive, the race had already been lost. Sales numbered in the hundreds while Geeps sold by the thousands. Some RS-11 orders were simply fallout from EMD's success — when they couldn't make Geeps fast enough, Alco got the overflow orders. While Alco soldiered on for another decade, introducing its Century series of locomotives, the RS-11 turned out to be the last Alco diesel that sold in significant numbers.

The RS-11 returns to the M.T.H. lineup for 2012, offered for the first time in a Premier version with Proto-Sound 3.0. This RS-11 can offer stiff competition for the Geeps and F-units on your railroad - or, like the prototype, you can mix them together in lashups, thanks to Proto-Sound 3.0 technology.



New York Central - RS-11 High Hood Diesel Engine

20-20213-1	Proto-Sound 3.0	\$429.95
20-20213-3	Non-Powered	\$199.95



Delaware & Hudson - RS-11 High Hood Diesel Engine

20-20211-1	Proto-Sound 3.0	\$429.95
20-20211-3	Non-Powered	\$199.95



Pennsylvania - RS-11 High Hood Diesel Engine

20-20214-1	Proto-Sound 3.0	\$429.95
20-20214-3	Non-Powered	\$199.95



New Haven - RS-11 High Hood Diesel Engine

20-20212-1	Proto-Sound 3.0	\$429.95
20-20212-3	Non-Powered	\$199.95

DL-109/110

diesel set



Features

- Directionally Controlled Headlight
- Intricately Detailed ABS Bodies
- Metal Wheels, Axles and Gears
- Die-Cast Truck Sides, Pilots and Fuel Tank
- (2) Remotely Controlled Proto-Couplers™
- Colorful Paint Scheme
- Metal Chassis
- (2) Precision Flywheel Equipped Motors In Each Unit
- Locomotive Speed Control In Scale MPH Increments
- Lighted Cab Interior
- (2) Engineer Cab Figures
- Moveable Roof Fan Blades
- Metal Body Side Grilles
- Operating Smoke Unit
- Proto-Sound® 3.0 With The Digital Command System Featuring Passenger Station Proto-Effects™
- Unit Measures: 19 3/8" x 2 1/2" x 3 3/4"
- Operates On O-42 Curves



The Otto Kuhler-designed DL-109 engines were ALCO's initial response to EMD's success with the streamlined E-series of road passenger locomotives. With its long, turned-up nose and smooth sides, the DL-109 helped to popularize the colorful paint schemes of the mid-twentieth century. The DL-109s were, like the E-Series, twin-engine 2000 horsepower units designed to be run in combination, with railroads piling on as many engines as it took to do the task at hand. ALCO also built matching B-units, dubbed DL-110s, for railroads interested in adding a cabless unit to the lash-up. Introduced

in 1941, the DL-109 was produced under the auspices of the War Production Board during World War II, when the production of other passenger diesels had been prohibited. At the end of the war, ALCO ceased to build the DL-109, shifting its efforts instead to the PA.

Now your railroad can benefit from this engine, which was sanctioned by the War Production Board and can bring additional legitimacy to any World War II-era layout.

Did You Know?

New Haven convinced the War Production Board to let them continue buying DL-109s throughout World War II because the engines were so productive. NH used them for both freight and passenger work, operating them almost 24 hours a day.



Santa Fe - DL-109/110 Diesel Engine Set
20-20226-1 Proto-Sound 3.0 \$629.95



New Haven - DL-109/110 Diesel Engine Set
20-20227-1 Proto-Sound 3.0 \$629.95



Rock Island - DL-109/110 Diesel Engine Set
20-20229-1 Proto-Sound 3.0 \$629.95



Southern - DL-109/110 Diesel Engine Set
20-20228-1 Proto-Sound 3.0 \$629.95

2500 HP Transfer diesel



Features

- Intricately Detailed ABS Body
- Die-Cast Truck Sides, Pilots and Fuel Tank
- Colorful Paint Scheme
- Metal Chassis
- Metal Handrails and Decorative Horn
- (2) Cab Figures
- Directionally Controlled Headlights
- Metal Wheels, Axles and Gears
- (2) Remotely Controlled Proto-Couplers™
- (2) Precision Flywheel Equipped Motors
- Locomotive Speed Control In Scale MPH Increments
- 1:48 Scale Proportions
- 2 Operating Smoke Units
- Proto-Sound 3.0 With The Digital Command System Featuring Freight Yard Proto-Effects™
- Unit Measures: 19 5/8" x 2 1/2" x 3 5/8"
- Operates On O-72 Curves





Elgin, Joliet & Eastern - 2500 HP Transfer Diesel Engine

20-20194-1	Proto-Sound 3.0	\$449.95
20-20194-3	Non-Powered	\$199.95

In 1950-1951, Lima-Hamilton built twenty-two colossal 2,500-hp transfer units for the Pennsylvania Railroad. These boxy center-cab units served for transfer work, which was similar to switching but on a larger scale. Rather than simply moving cars around a yard, these more powerful diesel engines moved cars from one yard to another, covering longer distances and heavier consists that would have been too challenging for many switchers. Although this large, dual-engine unit worked well for the PRR and its need to move coal cars from the mines to a central yard, such a large transfer unit proved too bulky and inflexible for many railroads, which opted for a cow-and-calf arrangement when they needed to perform heavier switching duties.

M.T.H. continues our proud tradition of offering models of unusual prototypes with an impressive, highly detailed version of this unique engine. With the realistic operation offered by Proto-Sound 3.0, it will add interest to your working layout.

Did You Know?

Lima-Hamilton built only these 22 transfer units, 136 switchers, and 16 road switchers before they were subsumed in a merger with Baldwin.



Pennsylvania - 2500 HP Transfer Diesel Engine

20-20193-1	Proto-Sound 3.0	\$449.95
20-20193-3	Non-Powered	\$199.95



SOO Line - 2500 HP Transfer Diesel Engine

20-20195-1	Proto-Sound 3.0	\$449.95
20-20195-3	Non-Powered	\$199.95



Santa Fe - 2500 HP Transfer Diesel Engine

20-20196-1	Proto-Sound 3.0	\$449.95
20-20196-3	Non-Powered	\$199.95

GP-35 Low Hood diesel



Features

- Directionally Controlled Headlights
- Intricately Detailed ABS Body
- Metal Wheels, Axles and Gears
- Die-Cast Truck Sides, Pilots and Fuel Tank
- Colorful Paint Scheme
- Metal Chassis
- Metal Handrails and Decorative Horn
- (2) Precision Flywheel Equipped Motors
- Locomotive Speed Control In Scale MPH Increments
- Proto-Scale 3-2 3-Rail/2-Rail Conversion Capable
- Lighted Cab Interior
- Illuminated Number Boards
- Lighted Marker Lights
- (2) Engineer Cab Figures
- Moveable Roof Fan Blades
- Metal Body Side Grilles
- Operating Smoke Unit
- (2) Remotely Controlled Proto-Couplers™
- Proto-Sound 3.0 With The Digital Command System Featuring Freight Yard Proto-Effects™
- Unit Measures: 14 3/4" x 2 1/2" x 4 5/16"
- High-Rail Wheels Operate on O-42 Curves
- Scale Wheels Operate on 31" Radius Curves



Produced from 1963 to 1966, the GP35, along with its six-axle SD35 sibling, marked both an end and a beginning. They were the last road diesels to use the EMD 567 motor that had powered switchers, F-units, and Geeps since 1939 (so named because each cylinder displaced 567 cubic inches). For the horsepower race of the 1960s, EMD tweaked the 567 to a turbocharged V-16 delivering 2500 hp. That was it for the 567, however, and in 1966 the baton was passed to the more powerful model 645. But while the "35 line" diesels ushered out an old motor, they inaugurated a new look. Their angled cab roofs and the clean, squared-off lines of their car bodies established the look of EMD power for the next three decades.

Introduced to compete with General Electric's landmark U25B, which had ushered in the second generation of diesel power, the GP35 outsold the "U-Boat" nearly three to one. There was a strong market for new power in the mid-1960s because the first-generation diesels that had vanquished steam were wearing out. While first-generation rosters had often been a hodgepodge of manufacturers and models as railroads experimented with the new technology, by 1960 Alco, EMD, and GE were the only manufacturers left standing - and Alco would soon throw in the towel. As a result, virtually every major U.S. railroad became a GP35 customer and over 1300 engines were sold in the United States, Canada, and Mexico.

While our Premier model is not the first O gauge version of this second-generation pioneer, it offers the best combination of detail, realism, and performance of any 1/48 scale GP35. Added-on detail parts include windshield wipers, metal see-thru body grilles, lift rings, metal grab irons and handrails, see-thru rooftop fan housings, and brake cylinders, air pipes, and swing hangers on our super-detailed Blomberg trucks. And in command mode with the DCS system, you can create a lashup combining one or more GP35s with other Proto-Sound 3.0 or Proto-Sound 2.0 first- or second-generation power, and run them from a single throttle just like the prototype.



Wisconsin Central - GP-35 Low Hood Diesel Engine with Proto-Sound 3.0

20-20201-1	Hi-Rail Wheels	\$429.95
20-20201-2	Scale Wheels	\$449.95
20-20201-3	Non-Powered	\$199.95



Baltimore & Ohio - GP-35 Low Hood Diesel Engine with Proto-Sound 3.0

20-20197-1	Hi-Rail Wheels	\$429.95
20-20197-2	Scale Wheels	\$449.95
20-20197-3	Non-Powered	\$199.95



Detroit Toledo & Ironton - GP-35 Low Hood Diesel Engine with Proto-Sound 3.0

20-20199-1	Hi-Rail Wheels	\$429.95
20-20199-2	Scale Wheels	\$449.95
20-20199-3	Non-Powered	\$199.95



Denver Rio Grande & Western - GP-35 Low Hood Diesel Engine with Proto-Sound 3.0

20-20198-1	Hi-Rail Wheels	\$429.95
20-20198-2	Scale Wheels	\$449.95
20-20198-3	Non-Powered	\$199.95



Guilford Rail - GP-35 Low Hood Diesel Engine with Proto-Sound 3.0

20-20200-1	Hi-Rail Wheels	\$429.95
20-20200-2	Scale Wheels	\$449.95
20-20200-3	Non-Powered	\$199.95

Premier Rolling Stock

Learn About **NEW** Monthly Freight Car Announcements!
Sign Up For Our **FREE E-Newsletter!**

M.T.H. Premier Line O Scale rolling stock freight and passenger cars are the perfect complement to any manufacturer's scale proportioned O Gauge locomotives. Built to 1:48 scale proportions, virtually every M.T.H. Premier Line freight or passenger car can be configured for use on 3 or 2-rail track powered by AC or DC power supplies.

Whether you prefer to purchase cars separately or assemble a unit train, M.T.H. Premier Line freight cars are available in a huge variety of styles and eras in as wide a selection of roadnames and paint schemes that you'll ever find. Virtually every car is offered in two car numbers which makes it even easier than ever to combine them into a multi-car consist.



Many of M.T.H.'s Premier Line Rolling Stock offerings can be easily retrofitted with scale Kadee® couplers thanks to the built-in coupler mounting pads. Swap out the 3-rail trucks for our 2-rail versions, and you'll be running on a scale 2-rail layout in no time. Keep the 3-rail trucks on and you'll find that most Premier Line freight cars operate on the tight O Gauge curves ensuring their versatility anywhere on your layout.



It is hard to match the excitement and beauty of a long, sleek passenger train speeding down the rails. M.T.H.'s Premier Line scale streamlined passenger cars and sets will bring exactly the right, realistic look to your passenger consists.

No other manufacturer matches the quality and value found inside an M.T.H. Premier Line passenger car. Using an intricately detailed, yet durable ABS body atop smooth rolling die-cast metal trucks results in a lightweight car that won't bog down a locomotive struggling to pull heavy aluminum

passenger cars. What's more, each Premier Line passenger car features detailed car interiors and overhead lighting for a realistic and authentic appearance.



40' AAR Box Car



Great Northern - 40' AAR Box Car
20-93552 \$54.95

**Look For Matching
6-Car Sets on Page 74**



New York Central - 40' AAR Box Car
20-93549 \$54.95

Features

- Die-Cast 4-Wheel Trucks
- Operating Die-Cast Metal Couplers
- Sliding Car Doors
- O Scale Kadee Compatible Coupler Mounting Pads
- 40' AAR Box Car Measures: 11 5/8" x 2 5/8" x 3 3/4"
- 40' Steel Sided Reefer Car Measures: 11 3/4" x 2 9/16" x 3 1/2"
- Operates On O-31 Curves

40' Steel Sided Reefer



Canadian National - 40' Steel Sided Reefer Car
20-94246 \$54.95

**Look For Matching
6-Car Sets on Page 75**



Pacific Fruit Express - 40' Steel Sided Reefer Car
20-94244 \$54.95

50' Waffle Box Car



Rock Island - 50' Waffle Box Car
20-93548 \$ 54.95



Norfolk Southern - 50' Waffle Box Car
20-93546 \$54.95



Canadian Pacific - Coil Car
20-98853 \$54.95

Coil Car

Features

- Operating Die-Cast Metal Couplers
- Fast-Angle Wheel Sets
- Needle-Point Axles
- 1:48 Scale Dimensions
- O Scale Kadee Compatible Coupler Mounting Pads
- 50' Waffle Box Car Features Sliding Car Doors
- Box Car Measures: 14 1/8" x 2 3/4" x 3 7/8"
- Coil Car Features (4) Individual Coil Spools
- Coil Car Features Removeable Coil Cover
- Coil Car Measures: 13" x 2 1/2" x 3 3/4"
- Both Operate On O-31 Curves



Pittsburgh & Lake Erie - Coil Car
20-98854 \$54.95

Ps-2 Hopper



Florida East Coast - Ps-2 Hopper Car
20-97290 \$49.95



Baltimore & Ohio - Ps-2 Hopper Car
20-97289 \$49.95

Features

- Operating Die-Cast Metal Couplers
- Fast-Angle Wheel Sets
- Needle-Point Axles
- 1:48 Scale Dimensions
- O Scale Kadee Compatible Coupler Mounting Pads
- Ps-2 Hopper Measures: 10" x 2 9/16" x 3 3/8"
- Ps-2CD High-Sided Hopper Measures: 14" x 2 11/16" x 3 13/16"
- Operates On O-31 Curves

Ps-2CD High-Sided Hopper



SOO Line - Ps-2CD High-Sided Hopper Car
20-97286 \$54.95



Milwaukee Road - Ps-2CD High-Sided Hopper Car
20-97285 \$54.95

2-Bay Fish Belly Hopper



Pennsylvania - 2-Bay Fish Belly Hopper Car
20-97293 \$54.95



Reading - 2-Bay Fish Belly Hopper Car
20-97292 \$54.95

**Look For Matching
6-Car Sets on Page 77**

Features

- Operating Die-Cast Metal Couplers
- Needle-Point Axles
- 1:48 Scale Dimensions
- O Scale Kadee Compatible Coupler Mounting Pads
- 2-Bay Fish Belly Hopper Measures: 14" x 2 11/16" x 3 13/16"
- 70-Ton 3-Bay Hopper Measures: 11" x 2 5/8" x 2 3/4"
- Both Operate On O-31 Curves

**Look For Matching
6-Car Sets on
Page 76**

70-Ton 3-Bay Hopper



CSX - 70-ton 3-Bay Hopper Car
20-97738 \$54.95



Chesapeake & Ohio - 70-ton 3-Bay Hopper Car
20-97739 \$54.95

Tank Car



Hooker Chemicals - Tank Car
20-96221 \$54.95



Diamond Shamrock - Tank Car
20-96219 \$54.95

8000 Gallon Tank



Velsicol - 8000 Gallon Tank Car
20-96215 \$49.95



Amaizo - 8000 Gallon Tank Car
20-96216 \$49.95

Features

- Operating Die-Cast Metal Couplers
- Fast-Angle Wheel Sets
- Needle-Point Axles
- 1:48 Scale Dimensions
- O Scale Kadee Compatible Coupler Mounting Pads
- Tank Car Measures: 14" x 2 11/16" x 3 13/16"
- 8000 Gallon Tank Measures: 9 1/16" x 2 3/4" x 3 7/8"
- Operates On O-31 Curves

Flat Car with R-36 Subway Car



Trailer Train - Flat Car with R-36 Subway Car
20-98869 \$109.95



Trailer Train - Flat Car with R-36 Subway Car
20-98868 \$109.95

Flat Car with M26 Pershing Tank



U.S. Army - Flat Car with M26 Pershing Tank
20-98857 \$69.95

Features

- Operating Die-Cast Metal Couplers
- Fast-Angle Wheel Sets
- Needle-Point Axles
- 1:48 Scale Dimensions
- O Scale Kadee Compatible Coupler Mounting Pads
- Flat with M26 Pershing Tank Measures: 14" x 2 11/16" x 3 13/16"
- Both Operate On O-31 Curves



Pennsylvania - Flat Car with M26 Pershing Tank
20-98856 \$69.95

Flat Car with (2) 20' Trailers



Reading - Flat Car with (2) 20' Trailers
20-98867 \$64.95



Canadian National - Flat Car with (2) 20' Trailers
20-98865 \$64.95

Flat Car with 48' Trailer



Triller Train - Flat Car with 48' Trailer
20-98863 \$64.95



Norfolk & Western - Flat Car with 48' Trailer
20-98860 \$64.95

Features

- Fast-Angle Wheel Sets
- Needle-Point Axles
- 1:48 Scale Dimensions
- (1) 48' Trailer
- Flat Car with (2) 20' Trailers Measures: 14 1/2" x 2 1/2" x 4 1/2"
- Flat car with 48' Trailer Measures: 14 1/2" x 2 1/2" x 4 1/2"
- Operates On O-31 Curves

Center Beam Flat Car with Log Load



Southern - Center Beam Flat Car with Log Load
20-98850 \$54.95



Canadian National - Center Beam Flat Car with Log Load
20-98851 \$54.95

Flat Car with Pipe Load



Union Pacific - Flat Car with Pipe Load
20-98843 \$54.95



Alaska - Flat Car with Pipe Load
20-98842 \$54.95

Features

- Fast-Angle Wheel Sets
- Needle-Point Axles
- 1:48 Scale Dimensions
- Removable Pipe or Log Load
- O Scale Kadee Compatible Coupler Mounting Pads
- Center Beam Flat Car Measures: 20" x 2 3/8" x 4 3/8"
- Center Beam Flat Car Operates On O-42 Curves
- Flat Car with Pipe Load Measures: 14 5/8 x 2 3/4 x 1 11/16
- Flat Car with Pipe Load Operates On O-31 Curves

Schnabel Flat Car



Westinghouse - Schnabel Flatcar
20-98870 \$119.95



Pennsylvania - Schnabel Flatcar
20-98871 \$119.95

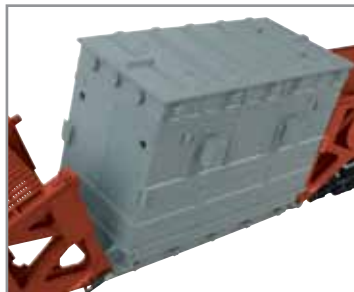

Features

- Operating Die-Cast Metal Couplers
- Fast-Angle Wheel Sets
- Needle-Point Axles
- 1:48 Scale Dimensions
- O Scale Kadee Compatible Coupler Mounting Pads
- Unit Measures: 26 1/2" x 3 3/16" x 4 7/8"
- Operates On O-72 Curves

55-Ton All Steel Drop Bottom Gondola



Canadian National - 55 Ton All Steel Drop Bottom Gondola Car
20-98837 \$54.95



Soo Line - 55 Ton All Steel Drop Bottom Gondola Car
20-98836 \$54.95

Features

- Operating Die-Cast Metal Couplers
- O Scale Kadee® Compatible Coupler Mounting Pads
- Fast-Angle Wheel Sets
- Needle-Point Axles
- 1:48 Scale Dimensions
- (5) Removeable LCL Containers
- Gondola Car with Coil Steel Load Measures: 14 5/8" x 2 5/8" x 3 15/16"
- Gondola Car with Coil Steel Load Operates On O-31 Curves
- 55-Ton Drop Bottom Gondola Measures: 11 1/2" X 2 5/8" X 2 1/2"
- 55-Ton Drop Bottom Gondola Operates On O-27 Curves



Lehigh Valley - Gondola Car with Coil Steel Load
20-98847 \$54.95

Gondola Car with Coil Steel Load



Chessie - Gondola Car with Coil Steel Load
20-98846 \$54.95

Bay Window Caboose



Delaware & Hudson - Bay Window Caboose
20-91365 \$59.95



CSX - Bay Window Caboose
20-91364 \$59.95



New York & Atlantic - Bay Window Caboose
20-91366 \$59.95



Caterpillar® - Bay Window Caboose
20-91363 \$59.95



Features

- Operating Die-Cast Metal Couplers
- Fast-Angle Wheel Sets
- Needle-Point Axles
- Unit Measures: 14 1/2" x 2 1/2" x 3 1/2"
- Operates On O-31 Curves



© 2011 Caterpillar
CAT, CATERPILLAR, their respective logos, "Caterpillar Yellow" and the "Power Edge" trade dress, as well as corporate and product identity used herein, are trademarks of Caterpillar and may not be used without permission.
www.cat.com
M.T.H. Electric Trains, a licensee of Caterpillar Inc.

Steel Caboose



Denver Rio Grande - Steel Caboose
20-91372 \$59.95



Santa Fe - Steel Caboose
20-91371 \$59.95



New York Central - Steel Caboose
20-91373 \$59.95



Detroit Toledo & Ironton - Steel Caboose
20-91374 \$59.95

Features

- Operating Die-Cast Metal Couplers
- O Scale Kadee Compatible Coupler Mounting Pads
- Needle-Point Axles
- 1:48 Scale Dimensions
- Caboose Interiors With Overhead Lighting
- Brakeman Figure
- 1:48 Scale Dimensions
- Unit Measures: 10 1/4" x 2 1/2" x 4 1/4"
- Operates On O-31 Curves

Center Cupola Steel Caboose



Chessie - Center Cupola Steel Caboose
20-91367 \$59.95



Atlantic Coast Line - Center Cupola Steel Caboose
20-91369 \$59.95



Western Maryland - Center Cupola Steel Caboose
20-91368 \$59.95



Conrail - Center Cupola Steel Caboose
20-91370 \$59.95



Features

- Detailed Car Interior
- Brakeman Figure
- Operating Die-Cast Metal Couplers
- Fast-Angle Wheel Sets
- Needle-Point Axles
- 1:48 Scale Dimensions
- Caboose Interiors With Overhead Lighting
- O Scale Kadee Compatible Coupler Mounting Pads
- Unit Measures: 9 1/8" x 2 7/16" x 3 3/4"
- Operates On O-31 Curves

6-Car 40' AAR Box Car Set

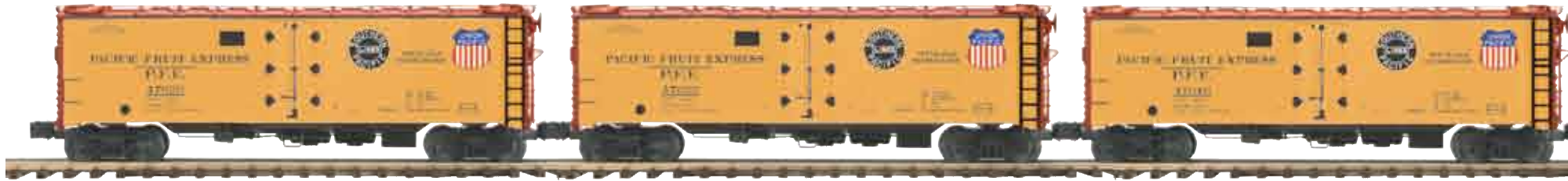

New York Central - 6-Car 40' AAR Box Car Set

20-90628	172528, 172522, 172546, 172549, 172564, 172560	\$279.95
20-90629	172533, 172537, 172552, 172556, 172571, 172578	\$279.95



State of Maine - 6-Car 40' AAR Box Car Set

20-90630	5410, 5418, 5422, 5425, 5436, 5434	\$279.95
20-90631	5412, 5417, 5420, 5428, 5433, 5439	\$279.95



Baltimore & Ohio - 6-Car 40' AAR Box Car Set

20-90632	466258, 466253, 466242, 466240, 466206, 466202	\$279.95
20-90633	466209, 466204, 466238, 466235, 466252, 466257	\$279.95



Great Northern - 6-Car 40' AAR Box Car Set

20-90634	2511, 2516, 2504, 2509, 2523, 2522	\$279.95
20-90635	2517, 2513, 2506, 2501, 2521, 2524	\$279.95

6-Car 40' Steel Sided Reefer



Pacific Fruit Express - 6-Car 40' Steel Sided Reefer Set

20-90646	47620, 47623, 47610, 47618, 47634, 47631	\$279.95
20-90647	47622, 47627, 47616, 47612, 47639, 47635	\$279.95



Santa Fe - 6-Car 40' Steel Sided Reefer Set

20-90644	4239, 4235, 4220, 4226, 4210, 4217	\$279.95
20-90645	4236, 4233, 4221, 4224, 4212, 4219	\$279.95



Burlington - 6-Car 40' Steel Sided Reefer Set

20-90648	74202, 74207, 74220, 74223, 74218, 74215	\$279.95
20-90649	74205, 74203, 74226, 74221, 74210, 74217	\$279.95



Canadian National - 6-Car 40' Steel Sided Reefer Set

20-90650	211663, 211665, 211679, 211672, 211682, 211687	\$279.95
20-90651	211650, 211652, 211649, 211645, 211637, 211634	\$279.95



6-Car 70-Ton 3-Bay Hopper Set



CSX - 6-Car 70-ton 3-Bay Hopper Car Set

20-90654	310036, 310050, 310022, 310047, 310034, 310058	\$279.95
20-90655	311728, 311732, 311733, 311740, 311749, 311756	\$279.95



Chesapeake & Ohio - 6-Car 70-ton 3-Bay Hopper Car Set

20-90656	101408, 101426, 101437, 101452, 101415, 101420	\$279.95
20-90657	101463, 101459, 101478, 101456, 101467, 101480	\$279.95



Pennsylvania Power & Light - 6-Car 70-ton 3-Bay Hopper Car Set

20-90658	129, 137, 134, 149, 142, 151	\$279.95
20-90659	138, 133, 147, 144, 156, 162	\$279.95



Norfolk Southern - 6-Car 70-ton 3-Bay Hopper Car Set

20-90652	9150, 9162, 9185, 9164, 9153, 9186	\$279.95
20-90653	9820, 9812, 9816, 9803, 9805, 9819	\$279.95

6-Car 2-Bay Fish Belly Hopper Sets



Reading - 6-Car 2-Bay Fish Belly Hopper Car Set

20-90638	89103, 89108, 89120, 89129, 89134, 89137	\$279.95
20-90639	89116, 89112, 89123, 89128, 89136, 89135	\$279.95



New Haven - 6-Car 2-Bay Fish Belly Hopper Car Set

20-90636	116042, 116045, 116053, 116059, 116064, 116066	\$279.95
20-90637	116044, 116049, 116055, 116058, 116062, 116063	\$279.95



Pennsylvania - 6-Car 2-Bay Fish Belly Hopper Car Set

20-90640	164280, 164286, 164275, 164273, 164264, 164262	\$279.95
20-90641	164283, 164289, 164292, 164297, 164255, 164250	\$279.95



Norfolk & Western - 6-Car 2-Bay Fish Belly Hopper Car Set

20-90642	59658, 59650, 59672, 59676, 59664, 59667	\$279.95
20-90643	59654, 59656, 59688, 59683, 59690, 59692	\$279.95



2-Car Spine Car Set with 48' Containers



Norfolk Southern - 2-Car Spine Car Set with (2) 48' Containers

20-95101 \$109.95



Canadian National - 2-Car Spine Car Set with (2) 48' Containers

20-95102 \$109.95



BNSF - 2-Car Spine Car Set with (2) 48' Containers

20-90103 \$109.95



CP Rail - 2-Car Spine Car Set with (2) 48' Containers

20-90104 \$109.95

6-Car Flat Car with M26 Pershing Tank



Pennsylvania - 6-Car Flat Car with M26 Pershing Tank

20-90660	473288, 473280, 473295, 473293, 473276, 473274	\$399.95
20-90661	473277, 473272, 473265, 473160, 473258, 473254	\$399.95



U.S. Army - 6-Car Flat Car with M26 Pershing Tank

20-90662	38462, 38460, 38453, 38458, 38446, 38445	\$399.95
20-90663	38420, 38426, 38419, 38412, 38405, 38404	\$399.95



Western Maryland - 6-Car Flat Car with M26 Pershing Tank

20-90664	2653, 2658, 2669, 2664, 2678, 2670	\$399.95
20-90665	2682, 2688, 2673, 2676, 2695, 2690	\$399.95



Bessemer & Lake Erie - 6-Car Flat Car with M26 Pershing Tank

20-90666	5422, 5429, 5425, 5437, 5430, 5434	\$399.95
20-90667	5428, 5423, 5426, 5433, 5439, 5435	\$399.95



Premier Passenger Cars



Southern - 5-Car 70' ABS Passenger Set (Ribbed)
20-65194 \$429.95



Southern - 2-Car 70' ABS Slpr/Diner Passenger Set (Ribbed)
20-66194 \$179.95



Southern - 70' ABS RPO Passenger Car (Ribbed)
20-68194 \$99.95



New Haven - 70' ABS RPO Passenger Car (Ribbed)
20-68197 \$99.95

Features

- Metal Wheels and Axles
- Overhead Interior Lighting
- Die-Cast 4-Wheel Trucks
- Operating Die-Cast Metal Couplers
- Colorful, Attractive Paint Schemes
- End-of-Car Diaphragms
- Separate Metal Handrails
- Fast-Angle Wheel Sets
- Needle-Point Axles
- Detailed Car Interiors
- 10 Passenger Figures In Each Coach Car
- 1:48 Scale Dimensions
- Detailed Car Undercarriage
- Sliding Baggage Car Doors
- 5-Car Sets Feature (1) Baggage, (3) Coaches, (1) Observation
- 5-Car Set Measures: 95" x 2 7/16" x 3 1/2"
- 2-Car 70' ABS Slpr/Diner Measures: 38" x 2 7/16" x 3 1/2"
- 2-Car 70' ABS Baggage/Coach Measures: 38" x 2 7/16" x 3 1/2"
- Vista Dome Measures: Measures: 19" x 2 7/16" x 3 1/2"
- 70' ABS RPO Passenger Car: 9" x 2 7/16" x 3 1/2"
- Operates On O-42 Curves



Southern - 70' ABS Full Length Vista Dome Passenger Car (Ribbed)
20-67194 \$99.95



Southern - 2-Car 70' ABS Baggage/Coach Passenger Set (Ribbed)
20-69194 \$179.95



New Haven - 70' ABS Full Length Vista Dome Passenger Car (Ribbed)
20-67197 \$99.95



New Haven - 2-Car 70' ABS Slpr/Diner Passenger Set (Ribbed)
20-66197 \$179.95



New Haven - 2-Car 70' ABS Baggage/Coach Passenger Set (Ribbed)
20-69197 \$179.95



New Haven - 5-Car 70' ABS Passenger Set (Ribbed)
20-65197 \$429.95



Santa Fe - 2-Car 70' ABS Slpr/Diner Passenger Set (Ribbed)
20-66196 \$179.95



Santa Fe - 70' ABS RPO Passenger Car (Ribbed)
20-68196 \$99.95



Santa Fe - 70' ABS Full Length Vista Dome Passenger Car (Ribbed)
20-67196 \$99.95



Santa Fe - 2-Car 70' ABS Baggage/Coach Passenger Set (Ribbed)
20-69196 \$179.95



Santa Fe - 5-Car 70' ABS Passenger Set (Ribbed)
20-65196 \$429.95



Rock Island - 70' ABS RPO Passenger Car (Ribbed)
20-68195 \$99.95



Rock Island - 2-Car 70' ABS Slpr/Diner Passenger Set (Ribbed)
20-66195 \$179.95



Rock Island - 2-Car 70' ABS Baggage/Coach Passenger Set (Ribbed)
20-69195 \$179.95



Rock Island - 70' ABS Full Length Vista Dome Passenger Car (Ribbed)
20-67195 \$99.95



Rock Island - 5-Car 70' ABS Passenger Set (Ribbed)
20-65195 \$429.95



2011 European Lineup

Due to the overwhelming popularity of our European line, MTH has decided to make it a staple in our catalogs. The enthusiastic response from our European customers and dealers has led us to expand the European lineup to include a bevy of electric and steam engines as well as passenger, box, gondola, and tank cars.

Does this mean we're paying less attention to American prototypes? Absolutely not. What it means for U.S. customers is some exciting new models to choose from, and the opportunity to spread our development costs over a wider customer base — which means more resources to come up with new features for all of our product lines. As an example, our expansion into the HO market has led us to develop smaller electronics packages that will eventually find their way into smaller, more realistic tenders for some O gauge steamers.

On the other side of the Pond, O gauge models are built to slightly different and slightly larger scales: 1:43.5 in England and France and 1:45 in the rest of Europe, compared to the 1:48 scale of American O Gauge. To ensure compatibility with existing European models, our European models will be built to the correct scales for their respective countries and delivered with both American and European couplers. Many European railroads, particularly in Britain, have a smaller maximum height than American railroads, so 1:43.5, 1:45 and 1:48 models will look and run fine with each other.

The European market is an expanding one, and due to the fact that there are not many O-scale locomotives currently being produced in Europe, MTH decided to seize the opportunity to create some of these unique products. Not only are we offering the European market some of the most highly detailed and technologically advanced locomotives on the market, but we are also bringing the U.S. market items that previously, could only be found in Europe.

Visit our European website at www.mthtrains.com/europe





Bavarian Class S 3/6 Express steam engine



Features

- Die-Cast Metal Chassis
- Authentic Paint Scheme
- Metal Wheels and Axles
- Constant Voltage Headlight
- Die-Cast Truck Sides
- Engineer and Fireman Figures
- Operating Firebox Glow
- Metal Handrails and Decorative Bell
- Decorative Metal Whistle
- Operating Marker Lights
- Lighted Cab Interior
- Synchronized Puffing ProtoSmoke™ System
- Operating Tender Back-up Light
- Operating Proto-Coupler (Hi-Rail Only)
- Locomotive Speed Control In Scale MPH Increments
- Die-Cast Boiler and Chassis
- Die-Cast Tender Body
- Precision Flywheel Equipped Motor
- Wireless Drawbar
- European NEM Fine Scale Couplers Included
- NEM 365 Coupler Pocket
- NEM 362 Lenz® Compatible Coupler Included
- CE Rated
- Sprung Bumpers
- 1:45 Scale Proportions
- On-Board DCC Receiver
- Proto-Sound® 3.0 With The Digital Command System Featuring Quillable Whistle With German Speaking Passenger Station Proto-Effects™
- Unit Measures:
 - 20 7/8" x 2 3/4" x 4 1/4"
- Hi-Rail Wheels Operate On O-42 Curves
- NEM 310/311 Standard Fine Scale Wheels Operate On 54" Radius Curves



In 1871, Germany became the last major European country to unify, combining a hodgepodge of kingdoms and duchies. But it would be another 50 years before the 11 provincial railroads were nationalized into the German Imperial Railway Company (DRG, with the logo DR). In the meantime, each road continued to develop its own locomotive designs. One of the best was the Class S 3/6 of the Royal Bavarian State Railways (abbreviated K. Bay. Sts. B. in German).

Regarded by European enthusiasts as one of the most beautiful and successful of all steam locomotives, the Class S 3/6 ("S" for schnellzuglok, indicating an express passenger engine, and 3/6 to indicate 3 powered axles, 6 axles total) was built by A G Maffei beginning in 1908 and showcased the talent of that firm's chief designer, Heinrich Leppla. The stylish conical smokebox front of the S 3/6 was complemented by a handsome holly green paint scheme. Two inboard high pressure cylinders and two outboard low pressure cylinders drove the center axle. The S 3/6 was one of the first European engines to follow the American practice of casting the cylinders and smoke box saddle as one huge casting, which gave the engine a distinctive look. The majority of the class were fitted with 74" drivers to conquer Bavaria's mountainous terrain. A smaller group of S 3/6 engines, however, was built with 79" drivers for high-speed service on flatter routes and acquired the nickname "High Steppers."

After nationalization in 1920, the engines were painted in the black and red Deutsche Reichsbahn (DR) scheme and became classes 18.3 through 18.5. While the DR intended to develop new standard engines of its own, the S 3/6 was deemed so good that the DR continued to order new engines of this 1908 design through 1931. The relatively light axle loading of the S 3/6, 18 tons, was also a plus, as the DR was behind schedule in upgrading main lines to its new 20-ton standard. So successful were the Bavarian Pacifics that they were chosen over more modern power to lead the glorious cream and blue Rheingold Express on part of its scenic route down the Rhine Valley, both before and after WWII. An S 3/6 could also be seen often on the point of the Orient Express.

Even after World War II, the aging engines continued to be great performers. A large number were modernized with new boilers and became the most economical steamers on the Deutsche Bundesbahn (DB), the new name for West Germany's railroad system. By the 1960s however, the S 3/6 class, which originally numbered 159 locomotives, had been retired, with a number of engines preserved in museums or in operating condition. This superbly detailed, smooth running model of one of Europe's favorite steam engines, is offered in original Royal Bavarian paint schemes and post-nationalization black and red.

Did You Know?

As reparations after World War I, three S 3/6 steamers went to Belgium and 16 were given to France.



KBayStsB - Bavarian S 3/6 Express Steam Locomotive (Era I; Blue with Black Wheels)

20-3398-1	Hi-Rail Wheels	\$1195.95
20-3398-2	Fine Scale Wheels	\$1195.95



KBayStsB - Bavarian S 3/6 Express Steam Locomotive (Era I; Green with Red Wheels)

20-3399-1	Hi-Rail Wheels	\$1195.95
20-3399-2	Fine Scale Wheels	\$1195.95



KBayStsB - Bavarian S 3/6 Express Steam Locomotive (Era I; Green with Black Wheels)

20-3400-1	Hi-Rail Wheels	\$1195.95
20-3400-2	Fine Scale Wheels	\$1195.95



DR - Deutsche Reichsbahn Class 18.4 Steam Locomotive (Era II; (Black with Red Wheels)

20-3401-1	Hi-Rail Wheels	\$1195.95
20-3401-2	Fine Scale Wheels	\$1195.95

EST Era II Class 241 A steam engine

Features

- Die-Cast Metal Chassis
- Authentic Paint Scheme
- Metal Wheels and Axles
- Constant Voltage Headlight
- Die-Cast Truck Sides
- Engineer and Fireman Figures
- Operating Firebox Glow
- Metal Handrails and Decorative Bell
- Decorative Metal Whistle
- Operating Marker Lights
- Lighted Cab Interior
- Operating Proto-Coupler™ (Hi-Rail Only)
- Synchronized Puffing ProtoSmoke™ System
- Operating Tender Back-up Light
- Locomotive Speed Control In Scale MPH Increments
- Die-Cast Boiler and Chassis
- Die-Cast Tender Body
- European NEM Fine Scale Couplers Included
- CE Rated
- Sprung Bumpers
- Precision Flywheel Equipped Motor
- Wireless Drawbar
- 1:43.5 Scale Proportions
- On-Board DCC Receiver
- Proto-Sound® 3.0 With The Digital Command System Featuring Quillable Whistle With French Speaking Passenger Station Proto-Effects™
- Unit Measures:
24 5/16" x 2 9/16" x 3 15/16"
- Hi-Rail Wheels Operate On O-42 Curves
- NEM 310/311 Standard Fine Scale Wheels Operate On 42" Radius Curves





SNCF - Era 4/5 Class 241A Steam Engine (Black with Red Stripes), Cab # 241-A-65

20-3406-1 Hi-Rail Wheels \$1195.95



EST - Era II Class 241A Steam Engine (Gray), Cab # 241-022

20-3402-1 Hi-Rail Wheels \$1195.95

20-3402-2 Fine Scale Wheels \$1195.95



ETAT - Era III Class 241A Steam Engine (Post-War Green/Black with Yellow Stripes), Cab # 241-A-4

20-3404-2 Fine Scale Wheels \$1195.95



EST - Era II Class 241A Steam Engine (1932 Green/Black with Red Stripes), Cab # 241-A-21

20-3405-1 Hi-Rail Wheels \$1195.95



SNCF - Era II Class 241A Steam Engine (Black with Red Stripes), Cab # 241-A-10

20-3426-1 Hi-Rail Wheels \$1195.95



EST - Era II Class 241A Steam Engine (1936 Black with Red Stripes), Cab # 241-011

20-3403-1 Hi-Rail Wheels \$1195.95

20-3403-2 Fine Scale Wheels \$1195.95

The 4-8-2 wheel arrangement — 241 in French parlance, which counts axles rather than wheels — represented the largest regular-production passenger locomotives ever to serve in France. The first of the type were 41 engines of class 241A, built starting in 1925 for the Chemins de Fer de l'Est (Eastern Railway), which ran due east from Paris to cities such as Nancy and Strasbourg.

Like most French express engines, the 241A was a de Glehn compound, a design that would seem frighteningly complex to engineers or shop crews anywhere outside of France. To make more efficient use of steam, a compound engine uses steam twice. Boiler steam is fed to high-pressure cylinders and then exhausted into one or two larger, low-pressure cylinders to work again before going up the stack. Following in the footsteps of their countryman Anatole Mallet, one of the earliest advocates of compounding, Alfred de Glehn and Gaston du Bousquet at the end of the nineteenth century designed a four-cylinder compound system, with high-pressure cylinders outside the frames and low-pressure cylinders inside the frames.

The original 241As worked well enough that 49 more were ordered for the Chemins de Fer de l'État (State Railways). A series of trials in 1933, however, showed the 241A was inferior to the smaller, famous Pacifics of the Paris-Orleans Railway, as rebuilt by André Chapelon, "the genius of French steam." As a result, the 241As — like several other classes of French steamers — were rebuilt along Chapelon lines, resulting in a 40% increase in horsepower with a 15% decrease in coal consumption. The rebuilt engines served the Est, Etat, and later the nationalized French railways (SNCF) into the 1960s. At least two are preserved: the prototype, No. 241A1, in the Cité du Train in Mulhouse, France, and 241A65, the largest hand-fired, operating steam engine in Europe (which barnstormed across Switzerland this past summer, doubleheading with postwar French steamer 241P17). Our superdetailed model of this premier French steamer — complete with French passenger station announcements and crew talk, and authentic French whistle — is as it appeared in Era II after Chapelon had worked his magic.

LMS Duchess Class

steam engine



Features

- Die-Cast Boiler and Tender Body
- 1:43.5 Scale Proportions
- Die-Cast Metal Chassis
- Authentic Paint Scheme
- Metal Wheels and Axles
- Constant Voltage Headlight
- Die-Cast Truck Sides
- Precision Flywheel Equipped Motor
- Engineer and Fireman Figures
- Operating Firebox Glow
- Metal Handrails and Decorative Bell
- Decorative Metal Whistle
- Operating Proto-Coupler (Hi-Rail Only)
- Lighted Cab Interior
- Locomotive Speed Control In Scale MPH Increments
- On Board DCC Receiver (Fine Scale Only)
- European NEM Fine Scale Couplers Included
- Proto-Scale 3-2™ 3-Rail/2-Rail Conversion Capable
- Synchronized Puffing ProtoSmoke™ System
- Wireless Drawbar
- Proto-Sound With The Digital Command System Featuring Quillable Whistle With Passenger Station Proto-Effects™
- Unit Measures:
23 7/16" x 2 11/16" x 4 5/16"
- Hi-Rail Wheels Operate On O-54 Curves
- NEM 310/311 Standard Fine Scale Wheels Operate On 42" Radius Curves

Did You Know?

The Railways Act of 1921 mandated the merger of Britain's myriad railways into four companies in 1923: the London, Midland & Scottish Railway (LMS), the London & North Eastern Railway (LNER), the Great Western Railway (GWR), and the Southern Railway (SR). In 1948, these four companies were nationalized to form British Railways.





British Railways - Duchess Class Duchess of Buccleuch Steam Engine
20-3367-1 Hi-Rail Wheels \$1195.95

In the years before World War II, Londoners had at least two ways to get to Scotland in style. From Kings Cross, one could speed up the East Coast main to Edinburgh on the LNER's Flying Scotsman, behind one of Nigel Gresley's handsome Pacifics - perhaps a streamlined A4 or maybe an older, apple-green A3. Or one could depart instead from Euston station on the LMS and fly northward to Glasgow on the Coronation Scot or the Royal Scot behind the most powerful steam locomotives in the land, William Stanier's Princess Coronation Class 4-6-2's.

Relive the glory days of LMS express passenger service with our superbly detailed Princess Coronation Class Pacific, complete with sounds recorded from the prototype Duchess of Sutherland, synchronized puffing smoke with prototypically correct chuffs per driver revolution, and station sounds for the Royal Scot.

Learn more about it: search on the item number for this model on the M.T.H. Web site for links to additional information on this locomotive and prototype British railroading.



British Railways - Duchess Class Duchess of Atholl Steam Engine
20-3371-1 Hi-Rail Wheels \$1195.95



**London, Midland and Scottish Railway
Duchess Class Duchess of Montrose Steam Engine**
20-3370-1 Hi-Rail Wheels \$1195.95
20-3370-2 Fine Scale Wheels \$1195.95



British Railways - Duchess Class Duchess of Abercorn Steam Engine
20-3369-1 Hi-Rail Wheels \$1195.95

TRAXX F140 AC-1

electric



Features

- Directionally Controlled Headlights
- Intricately Detailed ABS Body
- Metal Wheels, Axles and Gears
- Die-Cast Truck Sides, Pilots and Fuel Tank
- (2) Remotely Controlled Proto-Couplers (Hi-Rail Only)
- Colorful Paint Scheme
- Metal Chassis
- Metal Handrails and Decorative Horn
- (2) Precision Flywheel Equipped Motors
- Locomotive Speed Control In Scale MPH Increments
- Proto-Scale 3-2 3-Rail/2-Rail Conversion Capable
- Lighted Cab Interior
- (2) Engineer Cab Figures
- Metal Body Side Grilles
- European NEM Fine Scale Couplers Included
- Sprung Bumpers
- (2) Motorized (Inside) Pantographs
- LED Lighting Effects
- On Board DCC Receiver
- 1:45 Scale Proportions
- Proto-Sound 3.0 With The Digital Command System Featuring German Speaking Passenger or Freight Yard Proto-Effects
- Unit Measures:
16 3/16" x 2 1/2" x 4 5/16"
- Hi-Rail Wheels Operate On O-42 Curves
- NEM 310/311 Standard Fine Scale Wheels Operate On 31" Radius Curves





Railion - TRAXX F140 AC-1 Electric Engine

20-5656-1	Hi-Rail Wheels	\$449.95
20-5656-2	Fine Scale Wheels	\$499.95
20-5656-3	Non-Powered	\$219.95
20-5656-6	Non-Powered Scale Wheels	\$229.95



Cargo - TRAXX F140 AC-1 Electric Engine

20-5653-1	Hi-Rail Wheels	\$449.95
20-5653-2	Fine Scale Wheels	\$499.95
20-5653-3	Non-Powered	\$219.95
20-5653-6	Non-Powered Scale Wheels	\$229.95

Since the dawn of the Orient Express in 1883, Europeans have dreamed of a rail network that would transcend national borders. For more than a century, the best that that could be accomplished was the handoff of passenger or freight consists from one national rail system to another, usually stopping at the border to change motive power. Even when most of the continent went to overhead wires to supply motive power, voltage and current were often different from one country to another. Today, however, all that is changing. Sporting service names like "EuroCity" and slogans like "Connecting Europe," electric engines glide seamlessly and swiftly across borders, and carriers offer freight and passenger services that span many nations.

With locomotive and car manufacturing facilities on four continents, Bombardier has emerged as a leader in the manufacture of equipment for these multinational rail carriers. Starting with electric locomotive technology developed

by German firm Adtranz, which Bombardier acquired in 2001, Bombardier developed the TRAXX family of electric and diesel locomotives for service across Europe. TRAXX electrics feature modular construction and can be configured to run on multiple voltages and both AC and DC. Leading purchasers have included freight carriers with multinational networks, including Cargo, the freight division of the Swiss Federal Railways that runs through Germany, Switzerland, and Italy, and Railion, which spans Denmark, the Netherlands, Germany, Switzerland, and Italy.

The TRAXX electric offers a near-perfect combination of speed, safety, and practicality. Its streamlined shape is designed for aerodynamics but also for economical construction, being composed almost entirely of flat surfaces. The ends are raked at an angle that slices through the air - but a steeper, more streamlined angle was avoided in order to minimize air turbulence between the engine and the follow-

ing car. The controls, of course, are fully computerized with myriad safety systems. With up to 800 horsepower being delivered to each of its eight wheels, wheelslip control on the TRAXX was mandatory. Another system automatically ensures adherence to speed restrictions and trackside signals.

But the most practical feature of the TRAXX electric has nothing to do with speed or safety. It turns out the engine's smooth, flat sides make a perfect rolling billboard, either for publicizing the owner or selling ad space for additional revenue. The most complex images can be printed on a heavy plastic foil and applied neatly to the engine, and changed easily when necessary. Passenger engines based on the same platform have carried graphics publicizing rock musicals, vacation destinations, and even UNICEF.

TRAXX F140 AC-1

electric

Connecting Europe - TRAXX F140 AC-1 Electric Engine

20-5654-1	Hi-Rail Wheels	\$449.95
20-5654-2	Fine Scale Wheels	\$499.95
20-5654-3	Non-Powered	\$219.95
20-5654-6	Non-Powered Scale Wheels	\$229.95

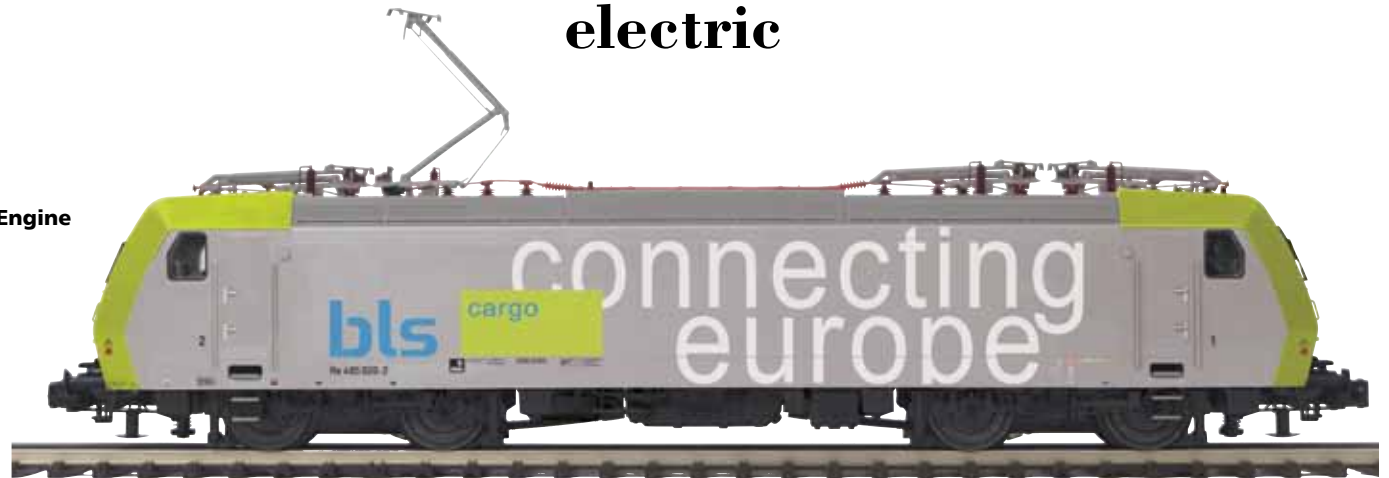

MRCE dispolok - TRAXX F140 AC-1 Electric Engine

20-5655-1	Hi-Rail Wheels	\$449.95
20-5655-2	Fine Scale Wheels	\$499.95
20-5655-3	Non-Powered	\$219.95
20-5655-6	Non-Powered Scale Wheels	\$229.95

Railion European - TRAXX F140 AC2 Electric Engine

20-5634-1	Hi-Rail Wheels	\$449.95
20-5634-2	Fine Scale Wheels	\$499.95
20-5634-3	Non-Powered	\$219.95



CrossRail - TRAXX P140 AC2 Electric Engine

- 20-5648-1 Hi-Rail Wheels \$449.95
- 20-5648-2 Fine Scale Wheels \$499.95



**SBB Cargo Switzerland
TRAXX F140 AC Electric Engine**

- 20-5632-1 Hi-Rail Wheels \$449.95
- 20-5632-2 Fine Scale Wheels \$499.95
- 20-5632-3 Non-Powered \$219.95

**Veolia Transport Germany
TRAXX P160 AC2 Electric Engine**

- 20-5633-1 Hi-Rail Wheels \$449.95
- 20-5633-2 Fine Scale Wheels \$499.95



Swiss 6/8 Type 2 Crocodile electric



Features

- Directionally Controlled Headlights
- Intricately Detailed Die-Cast Metal Body
- Metal Wheels, Axles and Gears
- Die-Cast Truck Sides, Pilots and Fuel Tank
- (2) Remotely Controlled Proto-Couplers™ (Hi-Rail Only)
- Colorful Paint Scheme
- Metal Chassis
- Metal Handrails and Decorative Horn
- (2) Precision Flywheel-Equipped Motors
- Locomotive Speed Control In Scale MPH Increments
- Proto-Scale 3-2 3-Rail/2-Rail Conversion Capable
- Lighted Cab Interior
- (2) Engineer Cab Figures
- Metal Body Side Grilles
- European NEM Fine Scale Couplers Included
- NEM 365 Coupler Pocket
- NEM 362 Lenz® Compatible Coupler Included
- Sprung Bumpers
- (2) Motorized Pantographs
- LED Lighting Effects
- On Board DCC Receiver
- 1:45 Scale Proportions
- Proto-Sound® 3.0 With The Digital Command System Featuring German Speaking Passenger or Freight Yard Proto-Effects™
- Unit Measures:
 - 17 9/16" x 2 1/2" x 3 3/4"
- Hi-Rail Wheels Operate On O-42 Curves
- NEM 310/311 Standard Fine Scale Wheels Operate On 36" Radius Curves





CE 6/8 II - Swiss 6/8 Type 2 Crocodile Electric Engine

20-5637-1 Hi-Rail Wheels \$899.95
 20-5637-2 Fine Scale Wheels \$899.95



BE 6/8 II - Swiss 6/8 Type 2 Crocodile Electric Engine

20-5638-1 Hi-Rail Wheels \$899.95
 20-5638-2 Fine Scale Wheels \$899.95

In a country famous for mountain railroading, the Gotthard route is the greatest challenge, the one by which the Swiss Federal Railways measures its locomotives. Constructed at a cost of more than 200 lives, the Gotthard line snakes its way around spiral tunnels, across more than a thousand bridges and open passages, and through narrow mountain valleys, culminating in a 2.6% climb to the 9-mile-long Goddard Tunnel — the longest in the world when it was opened in 1882. The Gotthard was the stomping ground for the 2-10-0 “Elephants,” the largest steam engines ever used in Switzerland. But when the decision was made to electrify the route, the Elephants were replaced by Crocodiles.

To conquer the Gotthard’s tight turns and steep grades, Swiss Locomotive and Machine Works (SLM) designed a freight locomotive in three articulated sections: a double-ended center section housing two engineer’s stations, twin pantographs, and the huge high voltage transformer; and two end sections, each with two electric motors powering a single jackshaft that transmitted power to the 53” drivers, using steam-locomotive-type drive rods. The jackshaft drive was dictated by the motors available at the time, which were too

large to be truck-mounted as in later designs. The nickname “crocodile” (krokodil in German) arose from the engine’s long articulated “snouts.”

In the 33 first-generation engines built in 1919–21, the powered jackshaft drove a main rod that was connected to both the first set of drivers and a second idler jackshaft. The 18 second-generation crocodiles, built in 1925–26, used a simpler arrangement with the powered jackshaft driving a main rod connected to the third set of drivers. In Swiss parlance, the two generations of engines were designated Ce 6/8II and Ce 6/8III (C for their speed range, maximum 40 mph (“A” being the fastest); e for electric; 6 indicating 6 driven axles; 8 signifying 8 axles total). Many were upgraded in the 1940s and ‘50s, raising their top speed to 47 mph and changing their class designation to Be 6/8. All crocodiles were delivered in brown paint, but many were later repainted green. Initial practice was to run with both pantographs raised, but some engines were later refitted with improved pans that allowed single-pantograph operation. The hugely successful Crocodiles ruled the Gotthard route into the 1950s, when they were displaced by newer power. Many worked into the

1970s on less strenuous routes and switching, and several have been preserved.

For American modelers, the Crocodile is perhaps the single most recognizable European locomotive, having been imported as a Märklin model in several scales since the 1930s. Like the Lionel Santa Fe F3, the Märklin HO Crocodile was a top of the line model that many boys of the 1950s and ‘60s dreamed of, but few actually owned. If you were one of those boys (or even if you weren’t), this new Premier model offers the chance to own the most detailed, smoothest running O gauge model of this iconic mountain goat ever made, available in both the original dual-jackshaft version and the later single-jackshaft style.

Did You Know?

The Gotthard Base Tunnel, currently under construction, will bore through the Alps at nearly ground level, almost 2000 feet below the existing Gotthard Tunnel. The new high-speed route will feature the world’s longest tunnel (35.4 miles) when it opens around 2018.

European Bierwagen reefer



Brasserie du Cardinal - European Bierwagen (Reefer Car)

20-99002 Hi-Rail Wheels \$69.95
20-99006 Fine Scale Wheels \$69.95



Feldschloesschen - European Bierwagen (Reefer Car)

20-99004 Hi-Rail Wheels \$69.95
20-99008 Fine Scale Wheels \$69.95



Brauerei Loewengarten - European Bierwagen (Reefer Car)

20-99003 Hi-Rail Wheels \$69.95
20-99007 Fine Scale Wheels \$69.95



Biere Beauregard - European Bierwagen (Reefer Car)

20-99001 Hi-Rail Wheels \$69.95
20-99005 Fine Scale Wheels \$69.95

Features

- Intricately Detailed Durable ABS Body
- Metal Wheels and Axles
- Die-Cast 2-Wheel Trucks
- Operating Die-Cast Metal Couplers (Hi-Rail Only)
- Colorful, Attractive Paint Schemes
- Fast-Angle Wheel Sets
- Needle-Point Axles
- 1:45 Scale Dimensions
- O Scale Kadee® Compatible Coupler Mounting Pads
- Sprung Bumpers
- CE Rated
- European NEM Fine Scale Couplers Included
- NEM 365 Coupler Pocket
- NEM 362 Lenz® Compatible Coupler Included
- Hi-Rail Wheels Operate On O-31 Curves
- NEM 310/311 Standard Fine Scale Wheels Operate On 31" Radius Curves



European Gedeckter Guterwagen box car



SBB-CFF - European Gedeckter Guterwagen (Box Car)

20-99012 Hi-Rail Wheels \$69.95
20-99016 Fine Scale Wheels \$69.95



Sihital Zurich Uetliberg Bahn - European Gedeckter Guterwagen (Box Car)

20-99011 Hi-Rail Wheels \$69.95
20-99015 Fine Scale Wheels \$69.95



SBB-CFF - European Gedeckter Guterwagen (Box Car)

20-99010 Hi-Rail Wheels \$69.95
20-99014 Fine Scale Wheels \$69.95



SBB-CFF - European Gedeckter Guterwagen (Box Car)

20-99009 Hi-Rail Wheels \$69.95
20-99013 Fine Scale Wheels \$69.95

Features

- Intricately Detailed Durable ABS Body
- Metal Wheels and Axles
- Die-Cast 2-Wheel Trucks
- Operating Die-Cast Metal Couplers (Hi-Rail Only)
- Colorful, Attractive Paint Schemes
- Fast-Angle Wheel Sets
- Needle-Point Axles
- 1:45 Scale Dimensions
- O Scale Kadee® Compatible Coupler Mounting Pads
- Sprung Bumpers
- CE Rated
- European NEM Fine Scale Couplers Included
- NEM 365 Coupler Pocket
- NEM 362 Lenz® Compatible Coupler Included
- Hi-Rail Wheels Operate On O-31 Curves
- NEM 310/311 Standard Fine Scale Wheels Operate On 31" Radius Curves



6-Car European Bierwagen Set



Biere Beauregard - 6-Car European Bierwagen (Reefer Car) Set

20-90900 Hi-Rail Wheels \$389.95
 20-90904 Fine Scale Wheels \$389.95



Brauerei Loewengarten - 6-Car European Bierwagen (Reefer Car) Set

20-90902 Hi-Rail Wheels \$389.95
 20-90906 Fine Scale Wheels \$389.95



Brasserie du Cardinal - 6-Car European Bierwagen (Reefer Car) Set

20-90901 Hi-Rail Wheels \$389.95
 20-90905 Fine Scale Wheels \$389.95

Feldschloesschen - 6-Car European Bierwagen (Reefer Car) Set

20-90903 Hi-Rail Wheels \$389.95
 20-90907 Fine Scale Wheels \$389.95

(Locomotive Not Included)



6-Car European Gedeckter Guterwagen Set



SBB-CFF - 6-Car European Gedeckter Guterwagen (Box Car) Set

20-90908 Hi-Rail Wheels \$389.95
20-90912 Fine Scale Wheels \$389.95

(Locomotive Not Included)



Sihital Zurich Uetliberg Bahn - 6-Car European Gedeckter Guterwagen (Box Car) Set

20-90909 Hi-Rail Wheels \$389.95
20-90913 Fine Scale Wheels \$389.95



SBB-CFF - 6-Car European Gedeckter Guterwagen (Box Car) Set

20-90910 Hi-Rail Wheels \$389.95
20-90914 Fine Scale Wheels \$389.95



SBB-CFF - 6-Car European Gedeckter Guterwagen (Box Car) Set

20-90911 Hi-Rail Wheels \$389.95
20-90915 Fine Scale Wheels \$389.95



European Modern Kesselwagen tank car



BP - European Modern Kesselwagen (Tank Car)

20-99017 Hi-Rail Wheels \$79.95
20-99021 Fine Scale Wheels \$79.95



Wascosa - European Modern Kesselwagen (Tank Car)

20-99019 Hi-Rail Wheels \$79.95
20-99023 Fine Scale Wheels \$79.95



Wascosa OMV - European Modern Kesselwagen (Tank Car)

20-99020 Hi-Rail Wheels \$79.95
20-99024 Fine Scale Wheels \$79.95



GATX - European Modern Kesselwagen (Tank Car)

20-99018 Hi-Rail Wheels \$79.95
20-99022 Fine Scale Wheels \$79.95

Features

- Intricately Detailed Durable ABS Body
- Metal Wheels and Axles
- Die-Cast 2-Wheel Trucks
- Operating Die-Cast Metal Couplers (Hi-Rail Only)
- Colorful, Attractive Paint Schemes
- Fast-Angle Wheel Sets
- Needle-Point Axles
- 1:45 Scale Dimensions
- O Scale Kadee® Compatible Coupler Mounting Pads
- Sprung Bumpers
- CE Rated
- European NEM Fine Scale Couplers Included
- NEM 365 Coupler Pocket
- NEM 362 Lenz® Compatible Coupler Included
- Hi-Rail Wheels Operate On O-31 Curves
- NEM 310/311 Standard Fine Scale Wheels Operate On 31" Radius Curves



European Modern Offener Guterwagen gondola car



DB Cargo - European Modern Offener Guterwagen (Gondola Car)

20-99025 Hi-Rail Wheels \$79.95
20-99029 Fine Scale Wheels \$79.95



Railion - European Modern Offener Guterwagen (Gondola Car)

20-99027 Hi-Rail Wheels \$79.95
20-99031 Fine Scale Wheels \$79.95



Niederlandischen Eisenbahnen - European Modern Offener Guterwagen (Gondola Car)

20-99026 Hi-Rail Wheels \$79.95
20-99030 Fine Scale Wheels \$79.95



SBB-CFF - European Modern Offener Guterwagen (Gondola Car)

20-99028 Hi-Rail Wheels \$79.95
20-99032 Fine Scale Wheels \$79.95

Features

- Intricately Detailed Durable ABS Body
- Metal Wheels and Axles
- Die-Cast 2-Wheel Trucks
- Operating Die-Cast Metal Couplers (Hi-Rail Only)
- Colorful, Attractive Paint Schemes
- Fast-Angle Wheel Sets
- Needle-Point Axles
- 1:45 Scale Dimensions
- O Scale Kadee® Compatible Coupler Mounting Pads
- Sprung Bumpers
- CE Rated
- European NEM Fine Scale Couplers Included
- NEM 365 Coupler Pocket
- NEM 362 Lenz® Compatible Coupler Included
- Hi-Rail Wheels Operate On O-31 Curves
- NEM 310/311 Standard Fine Scale Wheels Operate On 31" Radius Curves



6-Car European Modern Kesselwagen Set



Wascosa OMV - 6-Car European Modern Kesselwagen (Tank Car) Set

20-90919 Hi-Rail Wheels \$439.95
 20-90923 Fine Scale Wheels \$439.95



GA|TX - 6-Car European Modern Kesselwagen (Tank Car) Set

20-90917 Hi-Rail Wheels \$439.95
 20-90921 Fine Scale Wheels \$439.95



BP - 6-Car European Modern Kesselwagen (Tank Car) Set

20-90916 Hi-Rail Wheels \$439.95
 20-90920 Fine Scale Wheels \$439.95

Wascosa - 6-Car European Modern Kesselwagen (Tank Car) Set

20-90918 Hi-Rail Wheels \$439.95
 20-90922 Fine Scale Wheels \$439.95



(Locomotive Not Included)

6-Car European Modern Offener Güterwagen Set



DP Cargo - 6-Car European Modern Offener Güterwagen (Gondola Car) Set

20-90924 Hi-Rail Wheels \$439.95
 20-90928 Fine Scale Wheels \$439.95

(Locomotive Not Included)



Railion - 6-Car European Modern Offener Güterwagen (Gondola Car) Set

20-90926 Hi-Rail Wheels \$439.95
 20-90930 Fine Scale Wheels \$439.95



Niederländischen Eisenbahnen - 6-Car European Modern Offener Güterwagen (Gondola Car) Set

20-90925 Hi-Rail Wheels \$439.95
 20-90929 Fine Scale Wheels \$439.95



SBB-CFF - 6-Car European Modern Offener Güterwagen (Gondola Car) Set

20-90927 Hi-Rail Wheels \$439.95
 20-90931 Fine Scale Wheels \$439.95



European Passenger Cars



British Railways (Crimson & Cream) - 4-Car LMS Standard Passenger Set

20-60008 Hi-Rail Wheels \$429.95
 20-60008-2 Fine Scale Wheels \$429.95



British Railways (Maroon) - 4-Car LMS Standard Passenger Set

20-60011 Hi-Rail Wheels \$429.95
 20-60011-2 Fine Scale Wheels \$429.95

British Railways (Maroon) - LMS Standard Passenger Car

20-60013 Hi-Rail Wheels \$109.95
 20-60013-2 Fine Scale Wheels \$109.95



London, Midland & Scottish Railway - 4-Car LMS Standard Passenger Set

20-60005 Hi-Rail Wheels \$429.95
 20-60005-2 Fine Scale Wheels \$429.95



SNCF - 5-Car OCEM Passenger Car Set

20-60019 Hi-Rail Wheels \$549.95
 20-60019-2 Fine Scale Wheels \$549.95





British Railways - (Crimson & Cream) LMS Standard Baggage Car
 20-60009-2 Fine Scale Wheels \$109.95



British Railways (Crimson & Cream) - LMS Standard Passenger Car
 20-60010 Hi-Rail Wheels \$109.95
 20-60010-2 Fine Scale Wheels \$109.95



British Railways (Maroon) - LMS Standard Baggage Car
 20-60012-2 Fine Scale Wheels \$109.95



London, Midland & Scottish Railway - LMS Standard Baggage Car
 20-60006-2 Fine Scale Wheels \$109.95



London, Midland & Scottish Railway - LMS Standard Passenger Car
 20-60007 Hi-Rail Wheels \$109.95
 20-60007-2 Fine Scale Wheels \$109.95



Features

- Intricately Detailed Durable ABS Body
- Metal Wheels and Axles
- Die-Cast 2-Wheel Trucks
- Operating Die-Cast Metal Couplers (Hi-Rail Only)
- Colorful, Attractive Paint Schemes
- Fast-Angle Wheel Sets
- Needle-Point Axles
- 1:45 Scale Dimensions
- O Scale Kadee Compatible
- Coupler Mounting Pads
- Sprung Bumpers
- CE Rated
- European NEM Fine Scale Couplers Included
- NEM 365 Coupler Pocket
- NEM 362 Lenz® Compatible Coupler Included
- Hi-Rail Wheels Operate On O-72 Curves
- NEM 310/311 Standard Fine Scale Wheels Operate On 31" Radius Curves

European Passenger Cars



Deutsche Reichsbahn - 5-Car Rheingold Standard Passenger Set

20-60017 Hi-Rail Wheels \$549.95
20-60018 Fine Scale Wheels \$549.95



Orient Express (Blue) - 5-Car Orient Express Passenger Set

20-60004 Hi-Rail Wheels \$549.95
20-60004-2 Fine Scale Wheels \$549.95



Orient Express (Blue) - 5-Car Orient Express Add-On Passenger Set

20-60022 Hi-Rail Wheels \$549.95
20-60023 Fine Scale Wheels \$549.95



Orient Express (Brown) - 5-Car Orient Express Add-On Passenger Set

20-60024 (Hi-Rail Wheels) \$549.95
20-60025 Fine Scale Wheels \$549.95



Orient Express (Brown) - 5-Car Orient Express Passenger Set

20-60020 (Hi-Rail Wheels) \$549.95
20-60021 Fine Scale Wheels \$549.95



POWER UP

with the Best Transformers in 0 Gauge



100 Watts

Z-1000™ AC Transformer
40-1000 \$ 99.95
With 14 Volt Accessory Port

Whether you operate with conventional AC power or the M.T.H. Digital Command System (DCS), our UL-approved transformers offer the best way to power your layout. Choose the 100-watt Z-1000™ for a small- to medium-sized layout, or step up to the 400-watt, feature-laden Z-4000®, the most powerful UL-approved transformer in the hobby. All M.T.H. transformers offer

- Incredibly smooth, wide range throttle for precise speed control
- Bell and whistle/horn buttons that work with all makes of locomotives
- Fast-acting circuit breakers to protect your equipment
- Continuous useable wave power output compatible with all AC-powered engines

RealTrax Wire Harness
40-1015 \$4.99



WHY THE OR LISTING?

To protect our customers and their trains, M.T.H. Electric Trains is committed to manufacturing safe, UL or CSA approved transformers and power supplies. By subjecting our transformers to the strenuous tests and requirements of Underwriters Laboratories and/or CSA, M.T.H. helps ensure that our products meet the same requirements as other consumer electronics sold today. When choosing a new transformer, model railroaders should only look for those that have received a UL or CSA listing.



Z-DC300 30 Watt DC Transformer

40-300 \$ 79.95
Featuring 30 watts of DC power and a 16 volt AC accessory port, the CSA approved DC-300 will comfortably run up to five HO locomotives.

- Controller LED On Light
- Overload Light
- Power On Switch
- Momentum Control
- Brake Control
- Direction Control
- Built-In Circuit Breaker Protection
- 30 Watt DC Power Supply w/16v AC Accessory Output Jacks

Z-500™ AC Transformer
40-500 \$ 59.95

Designed for smaller layouts, the Z-500 offers the same control features as the Z-1000 but with less power.



100-Watt Accessory AC Power Supply
40-1000a \$79.95



- Ideal for powering accessories, or for DCS users who don't need a conventional transformer
- TIU/Barrel Jack adapter available separately for easy connection to DCS Track Interface Unit (TIU)
- 18-volt track power output
- 14-volt accessory output

Z-DC1 Transformer
40-200 \$ 19.95

A perfect small DC power supply to power up accessory lights, the ZDC1 includes a smooth-feeling power knob atop its UL approved enclosure.

- U.L. Approved
- 20 Watts DC Max Power Output
- Smooth Operating Throttle Knob
- Built-In Circuit Breaker Protection



RailKing Controller Set
40-750C \$ 49.95

Includes Z-500/Z-750 transformer controller, RealTrax lock-on (40-1003), RealTrax wire harness (40-1015)

400 Watts! The Most Powerful Listed Transformer!

Learn More About It

The instruction manual for every M.T.H. transformer is available at www.mthtrains.com. Just look up the transformer in our Product Search feature.



Overload indicator

Smooth-operating, wide-range **dual throttles**

Smooth-operating, wide-range **dual throttles**

Dual ammeters

show how much current each throttle is using and warn of potential overloads

Power-on indicator

Dual digital voltmeters show how much power you're putting on the track

Bell and whistle-horn buttons compatible with all AC engines

Rear Panel Outputs

Programming button for original Proto-Sound and QSI® AC sound systems

Internal cooling fan

Direction button for each channel

UL Approved, patented design for continuous and safe maximum allowable power output at a sustained 18 volts RMS at 10 amps.

On-off switch with Accidental Startup Protection: If throttles are not in Off position when Z-4000 is turned on, no power will be applied to the track.



0-22 Volts Track Power (10 AMP) **10-Volt Accessory Power (3 AMP)** **14-Volt Accessory Power (3 AMP)** **0-22 Volts Track Power (10 AMP)**

Accepts bare wires, spade lugs, or banana plugs (recommended) for easy connections

Z-4000® Transformer
40-4000 \$ 439.95

Two AC throttles, each with its own complete set of controls, plus 10-volt and 14-volt AC accessory outputs

ScaleTrax™

Three-Rail Trains Look—and Run—Better on ScaleTrax



It's not about the track. Railroading is about huge machinery that makes the ground shake when it goes by. In model railroading, the track is just a stage setting that should make your trains look more real and more massive -- and no three-rail track does that better than ScaleTrax, the lowest-profile, best-running 3-rail O gauge track system.

Compare our track with 3-rail track systems from Atlas O and Ross Custom Switches, and check out the advantages of ScaleTrax

Track Features

- Solid, rust-proof nickel silver rails
- Durable ABS ties for years of use
- Easy, snap-together assembly
- Built-in electrical connections eliminate need for rail joiners or track pins
- Built-in Lockon receptacle in every track section
- Non-derailing switches
- Snap-in, reversible switch motors work on either side of track
- Compatible with virtually all three-rail locomotives and cars

Learn more about it: Download our new 16-page ScaleTrax brochure. Click the ScaleTrax logo at the bottom of our home page, www.mthtrains.com



More Realism

Prototypically scaled, lower profile rail and ties make your locomotives and rolling stock look more massive on ScaleTrax.



Lionel
Tubular



Gargraves



Atlas



ScaleTrax

Lower Cost

ScaleTrax track and switches are more affordable than comparable Atlas and Ross products.

Smaller Third Rail

The thinnest, lowest-profile center rail of any major track brand gives ScaleTrax a more realistic look.

Better Electrical Contact

Concealed, large, spring-loaded contacts deliver more secure electrical connections between track sections.

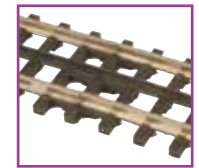
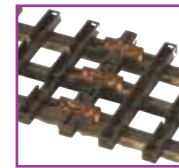
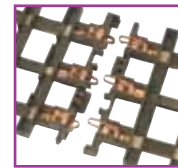

Smoother Switches

Thanks to our ramped and beveled frog and lower profile rail, ScaleTrax offers the smoothest-rolling switches in O gauge.



Easier-To-Use Flex Track

Low-profile rail and ties make ScaleTrax flex easier to bend than other brands.



Dave Hikel

Scale Trax™ Layout Packages

Don't have the time or inclination to design your own layout? Check out ScaleTrax layout packages, featuring track plans designed by Dave Hikel, renowned West Coast custom layout builder. Each package includes all the track and switches needed to build a complete layout. For details and track plans, click the ScaleTrax logo at the bottom of the M.T.H. home page, www.mthtrains.com. Order the ScaleTrax components from any M.T.H. Authorized Retailer and M.T.H. will drop ship your order directly from Maryland. If you prefer to design your own plan, use RR Track layout design software and take your design to any M.T.H. Authorized Retailer and we will drop ship the order for them.

8x9 Spare Room and Pacific RR

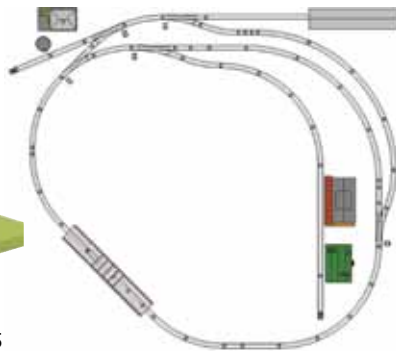

ScaleTrax™ Pieces

45-1105

Item #	Description	MSRP	QTY	Extension
45-1001	10 inch straight	\$ 3.99	9	\$35.91
45-1002	O-31 curve	\$ 3.99	0	\$0.00
45-1003	O-31 LH switch	\$ 49.95	0	\$0.00
45-1004	O-31 RH switch	\$ 49.95	0	\$0.00
45-1005	90 deg crossing	\$ 19.95	0	\$0.00
45-1006	45 deg crossing	\$ 19.95	0	\$0.00
45-1007	O-54 curve	\$ 3.99	19	\$75.81
45-1008	O-54 LH switch	\$ 49.95	1	\$49.95
45-1009	O-54 RH switch	\$ 49.95	3	\$149.85
45-1010	O-72 curve	\$ 4.99	7	\$34.93
45-1011	1.75 inch straight	\$ 2.49	5	\$12.45
45-1012	4.25 inch straight	\$ 3.50	3	\$10.50
45-1013	5 inch straight	\$ 3.50	2	\$7.00
45-1014	5.5 inch straight	\$ 3.50	2	\$7.00
45-1015	22.5 deg crossing	\$ 19.95	0	\$0.00
45-1019	30 inch straight	\$ 10.99	2	\$21.98
45-1020	O-72 RH switch	\$ 49.95	1	\$49.95
45-1021	O-72 LH switch	\$ 49.95	0	\$0.00
45-1025	bumper	\$ 15.95	2	\$31.90
45-1033	lock-on	\$ 3.99	8	\$31.92
45-1034	O-80 curve	\$ 5.99	1	\$5.99
45-1035	15" uncoupling section	\$ 19.95	0	\$0.00
45-1049	30 inch flex	\$ 9.95	0	\$0.00
45-1050	#4 LH switch	\$ 59.95	0	\$0.00
45-1051	#4 RH switch	\$ 59.95	0	\$0.00
45-1052	#6 LH switch	\$ 69.95	0	\$0.00
45-1053	#6 RH switch	\$ 69.95	0	\$0.00

45-1105

PACKAGE TOTAL: \$519.95



Roosevelt Junction

Roosevelt Junction starts small at just 4 ft. by 8 ft., but can grow in four phases to reach an awesome 8 ft. by 16 ft. railroading empire. Each 4 ft. by 8 ft. phase adds new operating possibilities. As you grown in the O Gauge railroading hobby, your layout can grow with you.

Roosevelt Junction - Phase 1

Roosevelt Junction begins as a small railroad with lots of fun. Sidings on both sides of the mainline allow for interesting switching operations between an engine yard and freights sidings. The mainline allows for continuous running when you want to sit back and watch the trains. The passing siding is long enough to accomidate most starter set trains, allowing two trains to pass each other.

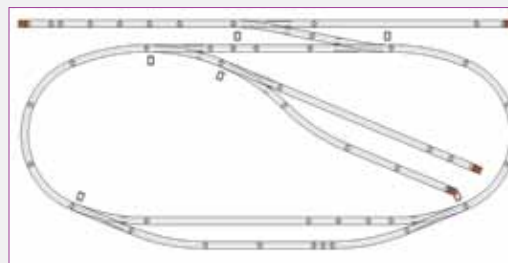

The O gauge layout that grows!

Build Roosevelt Junction in four phases.

Item #	Description	MSRP	QTY	Extension
45-1001	10 inch straight	\$ 3.99	6	\$23.94
45-1002	O-31 curve	\$ 3.99	6	\$23.94
45-1010	O-72 curve	\$ 4.99	5	\$24.95
45-1011	1.75 inch straight	\$ 2.49	3	\$7.47
45-1012	4.25 inch straight	\$ 3.50	6	\$21.00
45-1013	5 inch straight	\$ 3.50	1	\$3.50
45-1014	5.5 inch straight	\$ 3.50	6	\$21.00
45-1019	30 inch straight	\$ 10.99	3	\$32.97
45-1020	O-72 RH switch	\$ 49.95	3	\$149.85
45-1021	O-72 LH switch	\$ 49.95	1	\$49.95
45-1025	bumper	\$ 15.95	4	\$63.80
45-1033	lock-on	\$ 3.99	6	\$23.94
45-1051	#4 RH switch	\$ 59.95	2	\$119.90

45-1101

PACKAGE TOTAL: \$559.95

Roosevelt Junction

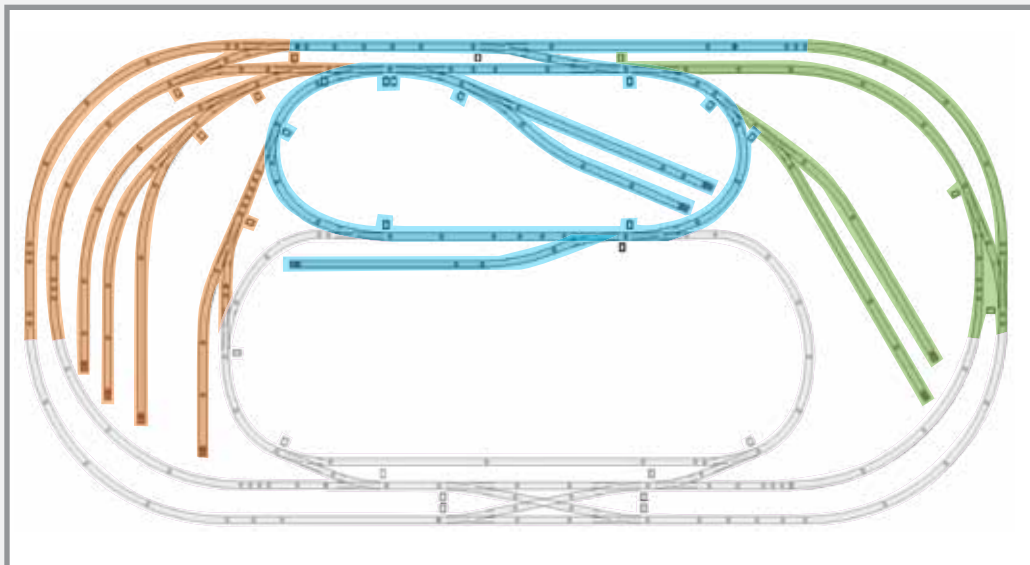

Roosevelt Junction - Phase 2

The second phase of Roosevelt junction adds numerous operating possibilities. The mainline doubles in length, yard capacity nearly triples, and a reversing wye allows entire trains to change direction.

Item #	Description	MSRP	QTY	Extension
45-1001	10 inch straight	\$ 3.99	3	\$11.97
45-1002	O-31 curve	\$ 3.99	3	\$11.97
45-1003	O-31 LH switch	\$ 49.95	1	\$49.95
45-1007	O-54 curve	\$ 3.99	3	\$11.97
45-1009	O-54 RH switch	\$ 49.95	1	\$49.95
45-1010	O-72 curve	\$ 4.99	11	\$54.89
45-1011	1.75 inch straight	\$ 2.49	11	\$27.39
45-1012	4.25 inch straight	\$ 3.50	2	\$7.00
45-1013	5 inch straight	\$ 3.50	3	\$10.50
45-1019	30 inch straight	\$ 10.99	2	\$21.98
45-1020	O-72 RH switch	\$ 49.95	6	\$299.70
45-1021	O-72 LH switch	\$ 49.95	2	\$99.90
45-1025	Bumper	\$ 15.95	4	\$63.80
45-1033	Lock-on	\$ 3.99	7	\$27.93
45-1034	O-80 curve	\$ 5.99	1	\$5.99

45-1102 **PACKAGE TOTAL: \$749.95**

Roosevelt Junction - Phase 3

The third phase of Roosevelt junction adds still more operating possibilities. The mainline again doubles in length and a long two-track spur is added making a perfect location for engine sheds or dead-end sidings.

Item #	Description	MSRP	QTY	Extension
45-1001	10 inch straight	\$ 3.99	6	\$23.94
45-1002	O-31 curve	\$ 3.99	2	\$7.98
45-1004	O-31 RH switch	\$ 49.95	1	\$49.95
45-1007	O-54 curve	\$ 3.99	2	\$7.98
45-1009	O-54 RH switch	\$ 49.95	1	\$49.95
45-1010	O-72 curve	\$ 4.99	5	\$24.95
45-1011	1.75 inch straight	\$ 2.49	5	\$12.45
45-1012	4.25 inch straight	\$ 3.50	1	\$3.50
45-1014	5.5 inch straight	\$ 3.50	1	\$3.50
45-1019	30 inch straight	\$ 10.99	2	\$21.98
45-1020	O-72 RH switch	\$ 49.95	2	\$99.90
45-1021	O-72 LH switch	\$ 49.95	1	\$49.95
45-1025	Bumper	\$ 15.95	1	\$15.95
45-1033	Lock-on	\$ 3.99	3	\$11.97
45-1034	O-80 curve	\$ 5.99	3	\$17.97

45-1103 **PACKAGE TOTAL: \$399.95**

Roosevelt Junction - Phase 4

The fourth and final addition to Roosevelt Junction transforms the layout into a hi-rail empire. The layout now sports a double track mainline with minimum O-72 curves as well as an interior O-31 loop allowing independent operations of three trains. Carefully located crossovers permit east access from either O-72 mainline into the yards. Three yard spurs connect to the mains with O-72 or larger curves so that even the largest articulated locomotives will feel right at home in Roosevelt Junction.

Item #	Description	MSRP	QTY	Extension
45-1001	10 inch straight	\$ 3.99	5	\$19.95
45-1007	O-54 curve	\$ 3.99	1	\$3.99
45-1008	O-54 LH switch	\$ 49.95	2	\$99.90
45-1009	O-54 RH switch	\$ 49.95	2	\$99.90
45-1010	O-72 curve	\$ 4.99	10	\$49.90
45-1011	1.75 inch straight	\$ 2.49	8	\$19.92
45-1013	5 inch straight	\$ 3.50	3	\$10.50
45-1014	5.5 inch straight	\$ 3.50	5	\$17.50
45-1015	22.5 deg crossing	\$ 19.95	1	\$19.95
45-1019	30 inch straight	\$ 10.99	2	\$21.98
45-1033	lock-on	\$ 3.99	5	\$19.95
45-1034	O-80 curve	\$ 5.99	4	\$23.96
45-1050	#4 LH switch	\$ 59.95	2	\$119.90
45-1051	#4 RH switch	\$ 59.95	2	\$119.90

45-1104 **PACKAGE TOTAL: \$749.95**

6x10 Main Street

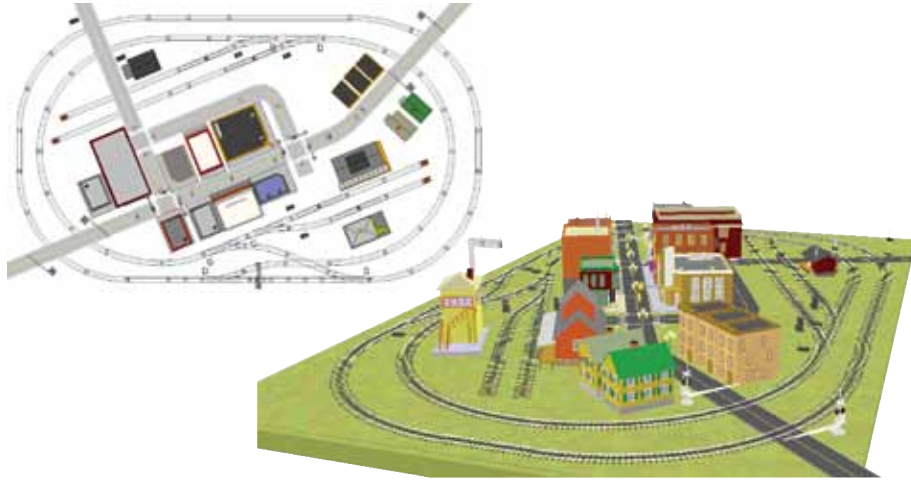

ScaleTrax™ Pieces

45-1107

Item #	Description	MSRP	QTY	Extension
45-1001	10 inch straight	\$ 3.99	10	\$39.90
45-1002	O-31 curve	\$ 3.99	0	\$0.00
45-1003	O-31 LH switch	\$49.95	0	\$0.00
45-1004	O-31 RH switch	\$49.95	0	\$0.00
45-1005	90 deg crossing	\$19.95	0	\$0.00
45-1006	45 deg crossing	\$19.95	0	\$0.00
45-1007	O-54 curve	\$ 3.99	30	\$119.70
45-1008	O-54 LH switch	\$49.95	3	\$149.85
45-1009	O-54 RH switch	\$49.95	3	\$149.85
45-1010	O-72 curve	\$ 4.99	2	\$9.98
45-1011	1.75 inch straight	\$ 2.49	3	\$7.47
45-1012	4.25 inch straight	\$ 3.50	5	\$17.50
45-1013	5 inch straight	\$ 3.50	2	\$7.00
45-1014	5.5 inch straight	\$ 3.50	0	\$0.00
45-1015	22.5 deg crossing	\$19.95	1	\$19.95
45-1019	30 inch straight	\$10.99	3	\$32.97
45-1020	O-72 RH switch	\$49.95	0	\$0.00
45-1021	O-72 LH switch	\$49.95	0	\$0.00
45-1025	Bumper	\$15.95	4	\$63.80
45-1033	Lock-on	\$ 3.99	0	\$0.00
45-1034	O-80 curve	\$ 5.99	4	\$23.96
45-1035	15" uncoupling section	\$19.95	4	\$79.80
45-1049	30 inch flex	\$ 9.95	0	\$0.00
45-1050	#4 LH switch	\$59.95	0	\$0.00
45-1051	#4 RH switch	\$59.95	0	\$0.00
45-1052	#6 LH switch	\$69.95	0	\$0.00
45-1053	#6 RH switch	\$69.95	0	\$0.00

45-1107

PACKAGE TOTAL: \$719.95

12x24 Timber Mountain



ScaleTrax™ Pieces

45-1106

Item #	Description	MSRP	QTY	Extension
45-1001	10 inch straight	\$ 3.99	14	\$55.86
45-1002	O-31 curve	\$ 3.99	0	\$0.00
45-1003	O-31 LH switch	\$49.95	0	\$0.00
45-1004	O-31 RH switch	\$49.95	0	\$0.00
45-1005	90 deg crossing	\$19.95	0	\$0.00
45-1006	45 deg crossing	\$19.95	2	\$39.90
45-1007	O-54 curve	\$ 3.99	10	\$39.90
45-1008	O-54 LH switch	\$49.95	0	\$0.00
45-1009	O-54 RH switch	\$49.95	0	\$0.00
45-1010	O-72 curve	\$ 4.99	41	\$204.59
45-1011	1.75 inch straight	\$ 2.49	4	\$9.96
45-1012	4.25 inch straight	\$ 3.50	5	\$17.50
45-1013	5 inch straight	\$ 3.50	1	\$3.50
45-1014	5.5 inch straight	\$ 3.50	2	\$7.00
45-1015	22.5 deg crossing	\$19.95	0	\$0.00
45-1019	30 inch straight	\$10.99	30	\$329.70
45-1020	O-72 RH switch	\$49.95	1	\$49.95
45-1021	O-72 LH switch	\$49.95	5	\$249.75
45-1025	Bumper	\$15.95	11	\$175.45
45-1033	Lock-on	\$ 3.99	30	\$119.70
45-1034	O-80 curve	\$ 5.99	22	\$131.78
45-1035	15" uncoupling section	\$19.95	0	\$0.00
45-1049	30 inch flex	\$ 9.95	23	\$228.85
45-1050	#4 LH switch	\$59.95	3	\$179.85
45-1051	#4 RH switch	\$59.95	5	\$299.75
45-1052	#6 LH switch	\$69.95	4	\$279.80
45-1053	#6 RH switch	\$69.95	3	\$209.85

45-1106

PACKAGE TOTAL: \$2599.95

ScaleTrax™

It takes **EIGHT O-31 CURVES** to make a circle.
 It takes **TWELVE O-54 CURVES** to make a circle.
 It takes **SIXTEEN O-72 CURVES** to make a circle.
 It takes **SIXTEEN O-80 CURVES** to make a circle.



STRAIGHT, FLEX & OPERATING TRACK SECTIONS



ScaleTrax™ - 1.75" Track Section
 45-1011 \$2.49
ScaleTrax™ - 1.75" Track Section 4-Pack
 45-1011-4 \$9.99

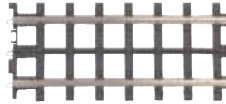

ScaleTrax™ - 5.0" Track Section
 45-1013 \$3.50

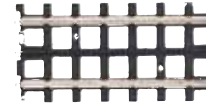

ScaleTrax™ - 4.25" Track Section
 45-1012 \$3.50
ScaleTrax™ - 4.25" Track Section 2-Pack
 45-1012-2 \$7.99

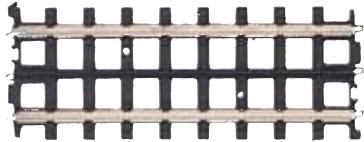

ScaleTrax™ - 5.5" Track Section
 45-1014 \$3.50
ScaleTrax™ - 5.5" Track Section 2-Pack
 45-1014-2 \$7.99

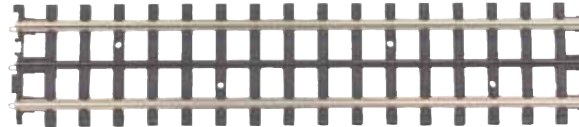

ScaleTrax™ - 10" Straight Track Section
 45-1001 \$3.99

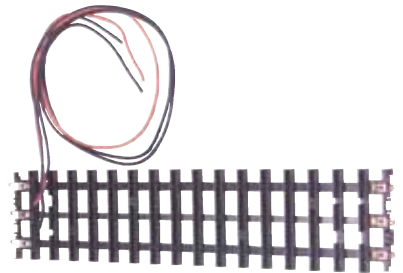

ScaleTrax™ - Lockon (Track Not Included)
 45-1033 \$3.99
 Each FlexTrack Section Requires 1 Lockon



ScaleTrax™ - 30" Track Section
 45-1019 \$10.99



ScaleTrax™ - 30" FlexTrack Section
 45-1049 \$9.95

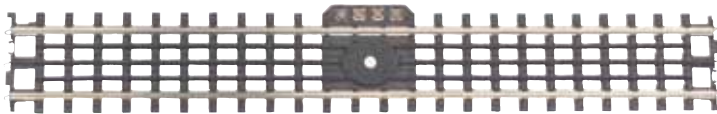

ScaleTrax™ - 15" Operating Track Section
 45-1035 \$19.95

Lowest Profile, Most Realistic 3-Rail Track in O Gauge!

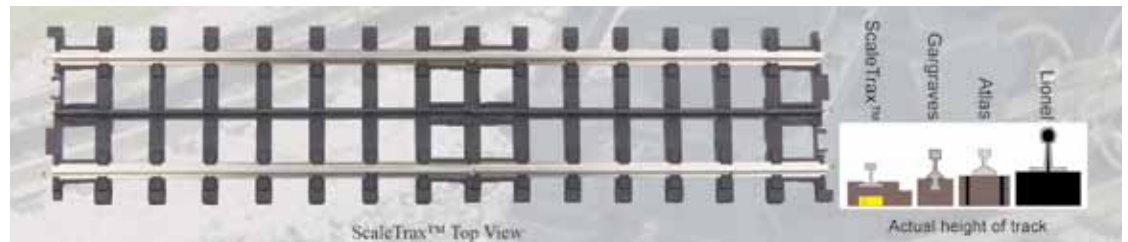

Curved Track Sections



ScaleTrax™ - O-31 Curved Track Section
45-1002 \$3.99

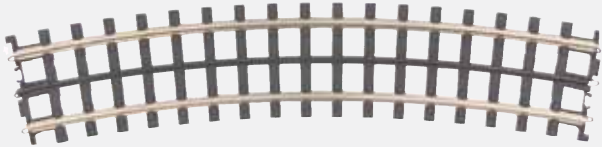

ScaleTrax™ - O-54 Curved Track Section
45-1007 \$3.99

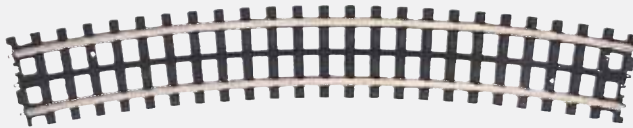

ScaleTrax™ - O-72 Curved Track Section
45-1010 \$4.99

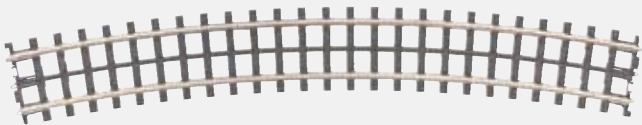

ScaleTrax™ - O-80 Curved Track Section
45-1034 \$5.99

Crossovers



ScaleTrax™ - 22.5 Degree Crossing
45-1015 \$19.95

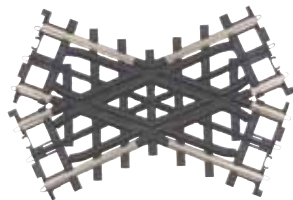

ScaleTrax™ - 45 Degree Crossing
45-1006 \$19.95

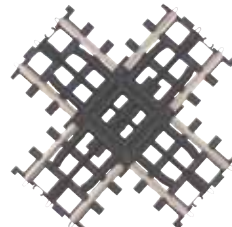

ScaleTrax™ - 90 Degree Crossing
45-1005 \$19.95

Switches

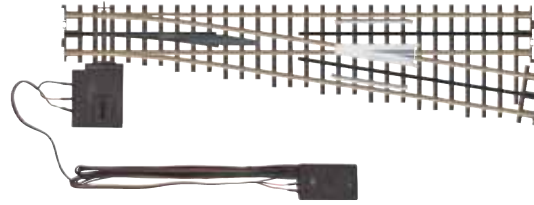

ScaleTrax™ - No. 6 Right Hand Switch
45-1053 \$69.95
ScaleTrax™ - No. 6 Left Hand Switch
45-1052 \$69.95

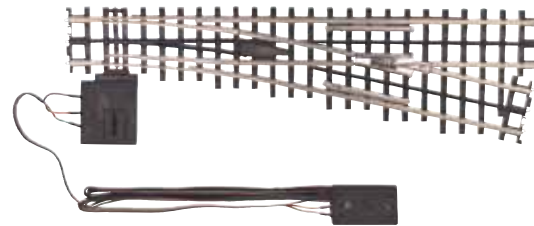

ScaleTrax™ - No. 4 Right Hand Switch
45-1051 \$59.95
ScaleTrax™ - No. 4 Left Hand Switch
45-1050 \$59.95

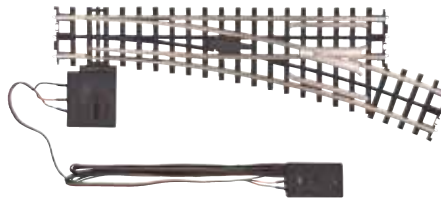

ScaleTrax™ - O-72 Right Hand Switch
45-1020 \$49.95
ScaleTrax™ - O-72 Left Hand Switch
45-1021 \$49.95

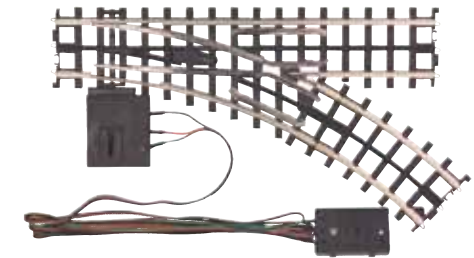

ScaleTrax™ - O-31 Right Hand Switch
45-1004 \$49.95
ScaleTrax™ - O-31 Left Hand Switch
45-1003 \$49.95

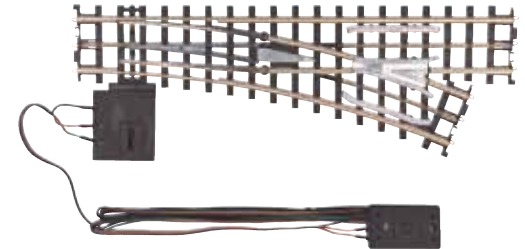

ScaleTrax™ - O-54 Right Hand Switch
45-1009 \$49.95
ScaleTrax™ - O-54 Left Hand Switch
45-1008 \$49.95

Accessories



ScaleTrax™ - Bumper
45-1025 \$15.95



ScaleTrax™ - ITAD
45-1028 \$34.95
(used to activate signals and trackside accessories)

RealTrax[®] : Rugged — Realistic — Reliable

REALTRAX[®]
BY M.T.H. ELECTRIC TRAINS

It takes **EIGHT O-31 CURVES** to make a circle.
It takes **TWELVE O-42 CURVES** to make a circle.
It takes **TWELVE O-54 CURVES** to make a circle.
It takes **SIXTEEN O-72 CURVES** to make a circle.
It takes **SIXTEEN O-82 CURVES** to make a circle.

At M.T.H. we believe a track system should allow your model railroad empire to grow. The RealTrax system includes 72 different components for maximum expansion capabilities. You'll find bridges, curves of all sizes, elevated and graduated trestles, crossovers, and every straight and curved configuration you'll need to create your own model railroad empire. And every piece of RealTrax is rugged, realistic, and reliable so you can have fun running your trains.

Rugged

Because most toy train empires begin on a carpet or floor, RealTrax is designed to hold up to the rigors of childhood play. Strong snap-together connections make it easy to assemble or change a layout in minutes. And the built-in roadbed helps keep dirt on the floor away from the wheels and gears of your trains.



Realistic

With its realistic cross-ties and ballasted roadbed, RealTrax looks like the mainline track used by heavy freights and high-speed passenger trains. Unlike older O gauge track with a round cross section, RealTrax uses flat-top "T"-rail like a real railroad.

Reliable

Nickel silver rail ensures that RealTrax will never rust. Spring-loaded phosphor bronze contacts provide superior electrical connections between track sections.

The contacts are spring loaded to maintain a solid connection over time and are highly resistant to corrosion of any kind. Similar materials are used in many electrical connections around your home, such as lamps, battery-operated appliances, and electrical outlets.

RealTrax switches feature the same durable construction as regular RealTrax sections and utilize long-lasting switch motors that provide precise throws every time. The reversible motor mechanism quickly snaps onto the other side of the switch if space is a problem. No disassembly of the switch is required! Lighted switch controllers allow you to throw a switch remotely from a distance, and lights on the controller indicate which direction the switch is thrown — green for straight and red for curved.

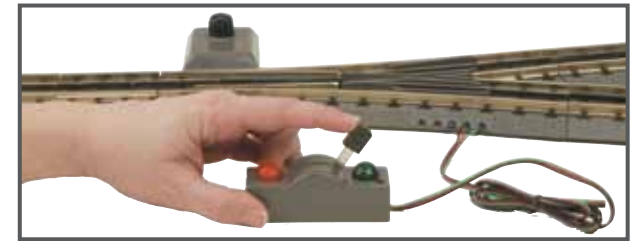

Crossovers & Operating Sections



**RealTrax - 90*
Crossover Track**
40-1006 \$24.99

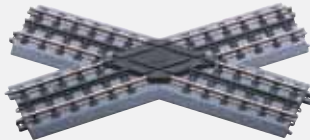

**RealTrax - 45*
Crossover Track**
40-1007 \$24.99



RealTrax - Operating Track Section
40-1008 \$29.95

Straight & Curved Track Sections



RealTrax - 30" Straight Track Section
40-1019 \$12.99



RealTrax - 10" Ground Track (2 pieces per pack)
40-1068-2 \$8.99
(features removable jumper connecting 2 outer rails)



**RealTrax
5.0" Track Section**
40-1016 \$3.99



RealTrax - 10" Straight Track Section
40-1001 \$4.49



**RealTrax
5.5" Track Section**
40-1012 \$3.99



RealTrax- O-82 Curved Track Section
40-1082 \$5.99



RealTrax - 3.5" Track Section
40-1018 \$3.99



RealTrax - 4.25" Track Section
40-1017 \$3.99



RealTrax- O-72 Curved Track Section
40-1010 \$5.99



RealTrax - O-42 Half Curve Track
40-1045 \$4.49



RealTrax - O-54 Half Curve Track
40-1057 \$4.99



RealTrax - O-31 Half Curve Track
40-1022 \$3.99



RealTrax - O-54 Curved Track Section
40-1054 \$4.99



RealTrax - Adapter Track Section
40-1011 \$8.99

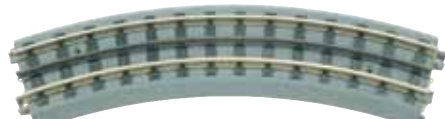

RealTrax - O-31 Curved Track Section
40-1002 \$4.49



RealTrax - O-72 Half Curved Track Section
40-1049 \$4.99



RealTrax - O-42 Curved Track Section
40-1042 \$4.99

Switches

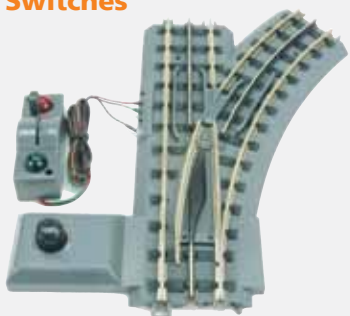

RealTrax - O-31 Switch (RH)
40-1004 \$64.95

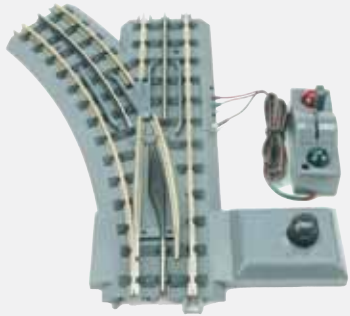

RealTrax - O-31 Switch (LH)
40-1005 \$64.95

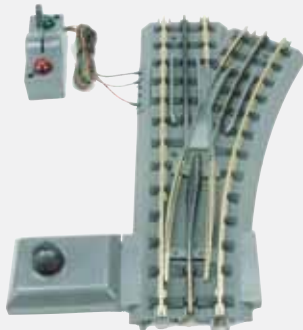

RealTrax - O-42 Switch (LH)
40-1043 \$74.95

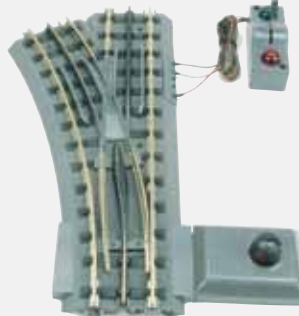

RealTrax - O-42 Switch (RH)
40-1044 \$74.95



RealTrax - 10" Insulated Straight Track Section Set
40-1029 \$8.99

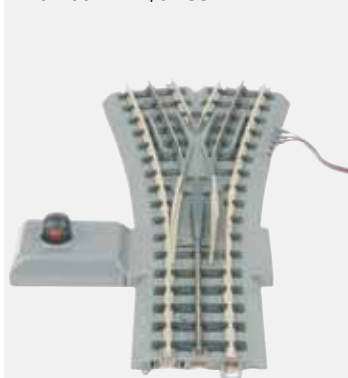

RealTrax- O-72 Wye Switch
40-1068 \$89.95



RealTrax - O-54 Switch (RH)
40-1055 \$79.95



RealTrax - O-54 Switch (LH)
40-1056 \$79.95

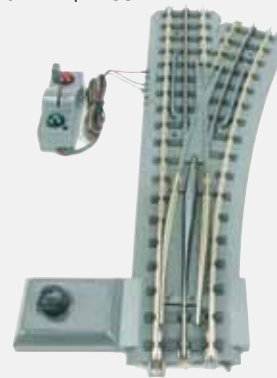

RealTrax - O-72 Switch (RH)
40-1020 \$89.95



RealTrax - O-72 Switch (LH)
40-1021 \$89.95



90 Degree 031 Curved Tunnel
40-1072 \$64.95
90 Degree 036 Curved Tunnel
40-1073 \$69.95



20" Single Track Straight Tunnel
40-1074 \$64.95

**Fully Sceniced,
Ready to Use!**



30" Dual Track Straight Tunnel
40-1075 \$69.95

**Track, Train & Trestles
NOT INCLUDED**



Over & Under Tunnel
40-1070 \$59.95

**100 WATT
POWER SUPPLY!**



Power & Track Pack
40-1071 \$149.95



**Bridges Now
Compatible
with Lionel®
Fastrack™**

O Steel Arch Bridge - Rust
40-1103 \$69.95
O Steel Arch Bridge - Silver
40-1101 \$69.95
O Steel Arch Bridge - Black
40-1105 \$69.95



O Subway Trestle Bridge
40-1048 \$29.95



O Bridge Girder - Rust
40-1104 \$29.95
O Bridge Girder - Silver
40-1102 \$29.95
O Bridge Girder - Black
40-1106 \$29.95



O 2-Track Bridge Girder - Rust
40-1110 \$34.95
O 2-Track Bridge Girder - Silver
40-1108 \$34.95
O 2-Track Bridge Girder - Black
40-1112 \$34.95



O 2-Track Steel Arch Bridge - Rust
40-1109 \$99.95
O 2-Track Steel Arch Bridge - Silver
40-1107 \$99.95
O 2-Track Steel Arch Bridge - Black
40-1111 \$99.95



Tunnel Portal - Single
40-9014 \$14.95



Tunnel Portal - Double
40-9015 \$19.95



RealTrax - 24-Piece Graduated Trestle System
40-1033 \$49.95



RealTrax - 8-Piece Elevated Trestle System
40-1034 \$29.95



8 Piece Elevated Subway Trestle Set
40-1047 \$29.95



RealTrax - Non-Slip Track Pads (50/pack)
40-1046 \$7.95

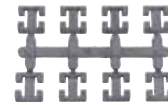

RealTrax - Track Clips (24)
40-1041 \$7.95

RealTrax - Lighted Lockon
40-1003 \$5.99



RealTrax - Track Activation Device (I.T.A.D.)
40-1028 \$24.95
(Allows passing train to activate signals or trackside accessories)



RealTrax - Track Cleaning Block
40-1099 \$17.99



RealTrax - Lighted Bumper
40-1024 \$14.95

Layout Builders

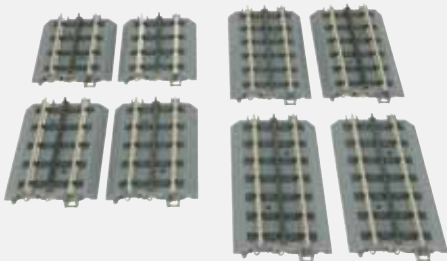

RealTrax - Layout Builder (8 Pcs)
40-1023 \$29.95
(Contains: (2) 3.5" Half Tracks, (2) 4.25" Half Tracks, (2) 5.0" Half Tracks, (2) 5.5" Half)



RealTrax - Right Hand Track Siding Layout Builder
40-1027 \$89.95
(Contains (1) Right-Hand O-31 Switch, (4) 10" Straights, (1) O-31 Curve, (1) RealTrax™ Bumper)



RealTrax - Left Hand Track Siding Layout Builder
40-1026 \$89.95
(Contains (1) Left-Hand O-31 Switch, (4) 10" Straights, (1) O-31 Curve, (1) RealTrax Bumper)

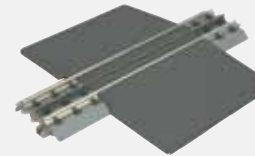

RealTrax - Grade Crossing
40-1009 \$9.95

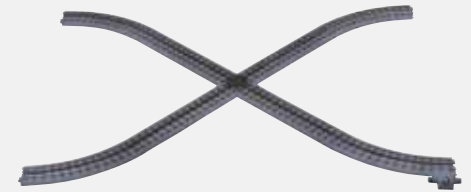

RealTrax - Figure 8 Layout Builder
40-1025 \$59.95
(Contains: (4) O-31 Curves, (4) 10" Straights, (1) Lighted Lockon, (1) 90 Degree Crossover)



RealTrax O-72 Wye Switch Spur Layout Builder
40-1069 \$149.95

O-Gauge or 2-Rail O Scale Couplers & Trucks

End-Of-Train-Device Roller Bearing Freight Truck

This long requested accessory can convert any M.T.H. Premier Line freight car to an end-of-train car in just minutes.

The all die-cast sprung roller bearing truck includes a center-rail pickup roller that powers a bright flashing LED, reproducing the end-of-train effect found on modern freight drags.

The ETD truck easily mounts to your existing freight cars in just a few minutes.



Features:

- Die-Cast Construction
- Fully Assembled
- Self-Powered Strobe Light
- Mounts To Any M.T.H. Freight Car
- Unit Measures: 1" High

White End-of-Train-Device Roller Bearing Freight Truck

20-89013 \$24.95

Yellow End-of-Train-Device Roller Bearing Freight Truck

20-89010 \$24.95

Locomotive Scale Coupler Kits:



No. 804 Kadee Coupler & Draft Gear Box Set

20-89018a \$3.90

No. 805 Kadee Coupler & Draft Gear Box Set

20-89019 \$3.90



Wireless Drawbar Set

20-89011 \$29.95

Conversion Wheel Kits

Ps2 Proto-Scale 3-2™ 4-Wheel Truck Scale Wheel Set Kit

20-89005 \$39.95

Ps2 Proto-Scale 3-2™ 6-Wheel Truck Scale Wheel Set Kit

20-89006 \$59.95

Ps2 Proto-Scale 3-2™ 4-Wheel Truck Hi-Rail Wheel Set Kit

20-89008 \$39.95

Ps2 Proto-Scale 3-2™ 6-Wheel Truck Hi-Rail Wheel Set Kit

20-89009 \$59.95

3-Rail

Railking 3-Rail Bettendorf Freight Car Two Truck Pack

30-89001 \$14.99

Railking 3-Rail Roller Bearing Freight Car Two Truck Pack

30-89002 \$14.99



Premier 3-Rail Bettendorf Freight Car Two Truck Pack

20-89003 \$14.99

Premier 3-Rail Roller Bearing Freight Car Two Truck Pack

20-89004 \$14.99



Premier 2-Rail

2-Rail Lightweight Passenger Car Two Truck Pack*

20-89007 \$24.95



2-Rail Heavyweight Passenger Car Two Truck Pack*

20-89014 \$24.95



2-Rail 64' Woodsided Passenger Car Two Truck Pack*

20-89012 \$24.95



2-Rail Bettendorf Caboose Truck Pack*

20-89015 \$17.95



2-Rail Bettendorf Freight Car Two Truck Pack

20-89001 \$17.95

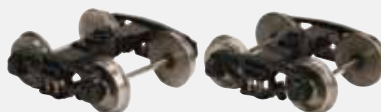

2-Rail Roller Bearing Caboose 2-Truck Pack*

20-89016 \$17.95



2-Rail CA-1 Caboose 2-Truck Pack

20-89017 \$17.99



2-Rail Roller Bearing Freight Car Two Truck Pack

20-89002 \$17.99

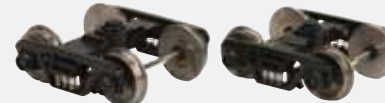

*Includes Removable 3-Rail Couplers

Accessories



#193 Industrial Water Tower
30-9029 \$54.95
Measures: 6 x 6 x 14 3/4



O-Scale Dwarf Signal
30-11011 \$24.95
Measures: 1" x 1 7/8" x 1 3/4"



"O" Operating Crossing Flasher Set w/Sound
30-11014 \$69.95
Measures: 5 1/2" x 2 1/2" x 1"



"O" Scale Modern Operating Crossing Signal
30-11006 \$59.95
Measures: 7" Tall



O Scale Vertical Signal
30-11036 \$49.95
Measures: 1 3/16 x 2 5/8 x 7 1/8



O-Scale Operating Crossing Gate Signal Set
30-11012 \$69.95
Measures: 8 1/2" x 2" x 8"



Harley-Davidson® - 4-Pack Motorcycle Set
30-90126 \$19.95
Measures: 2" Long x 1" High



Harley-Davidson® - 4-Pack Motorcycle Set
30-11077 \$19.95
Measures: 2" Long x 1" High



Brown & Black - Elevated Gate Tower
30-9097 \$29.95
Measures: 3 1/2" x 2 1/2" x 5 3/4"



O Scale Flashing Barricades
30-11021 \$34.95
Measures: 1" x 1" x 2"



© 2011 H-D, All Rights Reserved.

Accessories



Operating O Scale Water Tower
 30-11028 \$99.95
 Measures: 7 1/2" x 11" x 10 1/4"



Dual Stall Engine Shed
 30-90425 \$99.95
 Measures: 24" x 8 1/2" x 13 1/2"

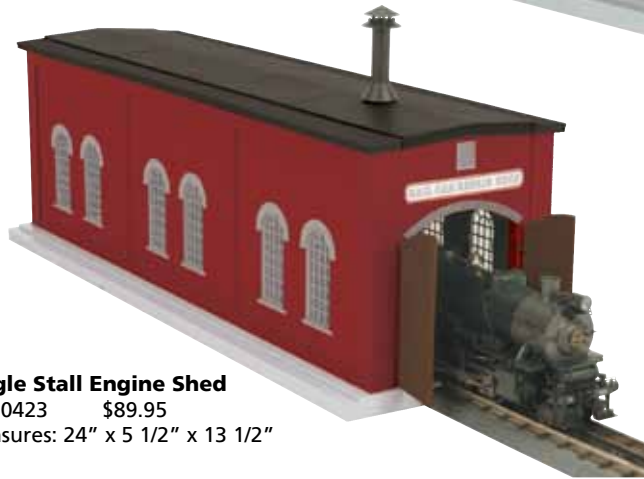

Single Stall Engine Shed
 30-90423 \$89.95
 Measures: 24" x 5 1/2" x 13 1/2"



Pennsylvania Single Stall Engine Shed
 30-90422 \$89.95
 Measures: 24" x 5 1/2" x 13 1/2"

Now Compatible
 with Lionel®
 Fastrack™



Budweiser Operating Freight Platform
 30-9171 \$59.95
 Measures: 9 3/4" x 3 1/2" x 3 3/4"

"© 2011 Anheuser-Busch, Inc. All Rights Reserved."



Pennsylvania Dual Stall Engine Shed
 30-90424 \$99.95
 Measures: 24" x 8 1/2" x 13 1/2"

Dark Red Stone - Passenger Station with Dual Platforms
 30-90094 \$99.95
 Measures: 39" x 10 1/2" x 8 1/2"



White & Red - #5 Country Church
 30-9057 \$34.95
 Measures: 7 7/8" x 4 5/8" x 10 9/16"



Greenville - Country Passenger Station
 30-90354 \$69.95
 Measures: 18 5/8" x 7 3/8" x 6 5/8"



Cream w/Green Shutters - #6 Farm House
 30-90332 \$44.95
 Measures: 7 1/2" x 7 1/2" x 7"



Light Blue & White - Row House #1
 30-90338 \$39.95
 Measures: 7 7/8" x 4 5/8" x 7"



Gray and White - Public Works Building
 30-90007 \$49.95
 Measures: 14 1/8" x 9 7/8" x 8 1/8"

Accessories

Eatie Gourmet's Grocery 3-Story City Building 1

30-90351 \$59.95

Measures: 8 1/4" x 10" x 10 1/8"



Metzger Butcher Shop - Opposite Corner Building with Blinking Sign

30-90341 \$54.95

Measures: 9 7/8" x 7 7/16" x 7 1/16"

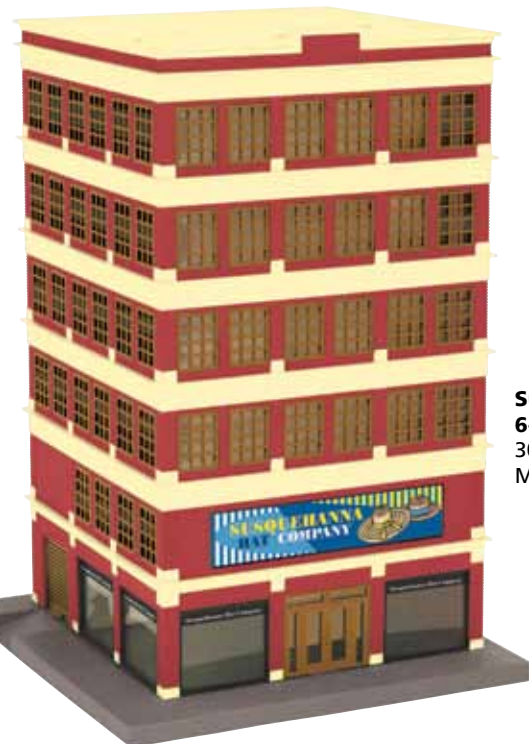

Susquehanna Hat Company 6-Story Department Store

30-90269 \$89.95

Measures: 11 1/16" x 11 1/16" x 16 7/8"



Floyd's Barber Shop - 3-Story City Building w/ Fire Escape & Blinking Sign

30-90410 \$69.95

Measures: 12 3/4" x 6 5/16" x 9 3/16"

Royal Flush Plumbing - Corner Building w/Blinking Sign

30-90389 \$54.95

Measures: 9 7/8" x 7 7/16" x 7 1/16"





Greenville Bank & Trust - Bank w/Coin Slot
 30-90349 \$69.95
 Measures: 9 1/2" x 17 15/16" x 9 1/8"



BP - Operating Gas Station
 30-9181 \$149.95
 Measures: 15 x 11 x 6 3/4



Gray & Black - Police Station
 30-9099 \$69.95
 Measures: 13 1/4" x 8 3/8" x 10"



Movie Theater
 30-9054 \$99.95
 Measures: 18 5/8 x 7 3/8 x 6 5/8

MTH Railroaders Club

Join The M.T.H. Railroaders Club

There are **EIGHT** different types of memberships, based on the style of model railroading that most interests you.

RAILKING MEMBERSHIP



30-75406 MTHRC 4-Bay Cylindrical Hopper Car
RailKing Membership is \$50.00

PREMIER MEMBERSHIP



20-98874 MTHRC Railgon Gondola Car with Coil Steel Load
Premier Membership is \$55.00

LIONEL CORP. STD. GAUGE MEMBERSHIP



11-30133 Lionel Corp. No. 214 Std. Gauge Box Car
Lionel Corp. 500 Series Membership is \$120.00

TINPLATE O GAUGE MEMBERSHIP



10-8083 MTHRC No. 2813 O Gauge Cattle Car
Tinplate 2800 Series Membership is \$90.00

TINPLATE STD. GAUGE MEMBERSHIP



10-2242 MTHRC No. 214 Std. Gauge Box Car
Tinplate 500 Series Membership is \$120.00

LIONEL CORP. O GAUGE MEMBERSHIP



11-70077 Lionel Corp. No. 2813 O Gauge Cattle Ca
Lionel Corp. 2800 Series Membership is \$90.00

BASIC MEMBERSHIP

60-1000 - The Basic Club Membership does not include a club car
Basic Membership is \$25.00

ONE-GAUGE MEMBERSHIP



70-78036 MTHRC Merchants Dispatch 40' Reefer Car
One-Gauge Membership is \$100.00

HO MEMBERSHIP



81-97019 MTHRC Waddell Coal USRA 55-Ton Steel Twin Hopper Car
HO Membership is \$30.00



GET THE MOST FROM MODEL RAILROADING
JOIN ONLINE! IT'S EASY — JUST GO TO WWW.MTHTRAINS.COM

As a member of the M.T.H. RailRoders Club you'll receive:

Limited-Edition Club Car



Each year we produce beautifully decorated cars exclusively for our Club members. Members automatically receive the car that matches their Club membership (RailKing, Premier, Tinplate Traditions or One Gauge) and have the option to collect other Club cars as well.

RailWare™ Software



Use your computer to design track layouts, search the database of all M.T.H. products, look at our past catalogs, listen to Proto-Sound 2.0 train effects, & much more. This Interactive DVD retails for \$79.95, but is yours FREE as a Club member.

The CrossingGate™ Club Magazine

You will receive our full-color Club magazines, jam-packed with product news, ideas from other members, rail history, & step-by-step articles explaining how M.T.H. technology can bring your railroad to life.



Club Card & Lapel Pin



Show the world your membership in this elite group of model railroaders with your high-quality embossed membership card & beautiful enameled lapel pin.

Proto-Sound 2.0 Upgrade Kits

Club members can save an additional 15% on these kits by visiting the MTHRC web page.

Club Web Site

Visit www.mthtrains.com and type in your member number to gain access to the Club web site. Here you can exchange messages with other Club members, keep up with the latest news, and even build your own homepage.

1st Class Mailing of M.T.H. Catalogs

Club Members get all M.T.H. catalogs earlier than other mailing list members, via First-Class mailings, so they can order from their local train store before the best items are sold out.

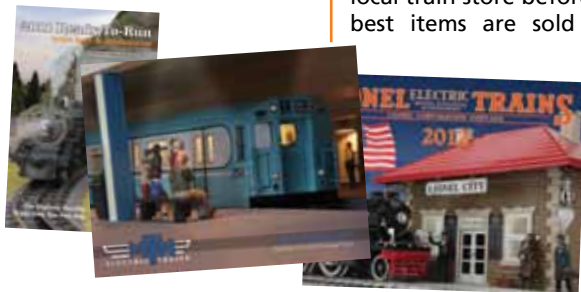

CARRY ON THE M.T.H. TRADITION WITH MEMORABILIA AND COLLECTIBLES

MTH Promotional DVD

This interactive DVD is packed full of sights & sounds guaranteed to make you rethink how far the hobby of model railroading has come. You'll learn about some of the most innovative products ever produced & marvel at the sophistication of a product line unmatched by other model train manufacturers.



Previous Year Club Cars

MTHRC members can still obtain earlier produced MTHRC cars by visiting the MTHRC pages on the website. Only MTHRC members can get these cars!



A Toy Train Story

This comprehensive book is a must for collectors & other lovers of toy trains. 350 pages & 1900 color photos, hard cover. Add this book to your membership for only \$25.00 (50% off the \$49.95 cover price)!



www.mthtrains.com

We don't think we're exaggerating when we say M.T.H. has the most useful train manufacturer's site on the Internet. Here's just a sample of the answers you can find online.



HOW DOES IT WORK?

Misplaced an instruction manual or just want to know how a product works? Use Product Search to look up the item and view its instruction manual.



① CAN I SEE AND HEAR IT IN ACTION ...?

Click on Video — only M.T.H. gives you the chance to see and hear locomotives and other products in action, before you buy.

② WHAT'S THE LATEST INFO ON ...?

Use Product Search to find the latest info on new products before they're delivered — sound sets, cab numbers, feature and paint scheme updates, and other information that arrived after the catalog was published.

DID YOU EVER MAKE?

Use Product Search to search through nearly all of the 17,000 items we've made in the past 30 years, for your favorite road name, engine, or type of rolling stock.

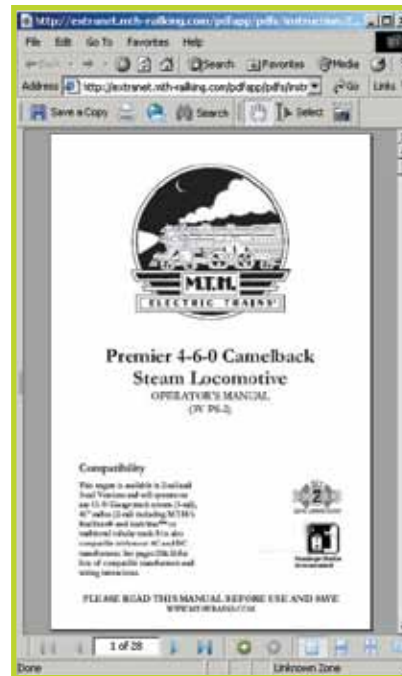

③ DOES ANY DEALER STILL HAVE ...?

Locate hard-to-find items with our Product Locator, which searches the inventories of M.T.H. dealers across the country.

④ WHEN IS IT COMING?

Our online Shipping schedule is updated frequently to let you know what's coming soon to your hobby shop.

⑤ ARE YOU GOING TO MAKE?

View the last several M.T.H. Catalogs online.

⑥ HOW CAN I FIX...?

The Service area of our site allows you to email a question to our factory technicians or find which of our 150+ local service centers is closest to you.

7 WHAT REPAIR PART DO I NEED?

Use Product Search to find exploded diagrams and parts lists for M.T.H. locomotives and accessories, and then order the parts online or by phone.

8 WHAT'S NEW?

New arrivals and other news are posted frequently on our home page.

HOW CAN I BE AMONG THE FIRST TO KNOW?

To get the news as it happens, sign up for our free weekly electronic newsletter, with information on new M.T.H. products, industry news, and sneak peeks at upcoming specials!

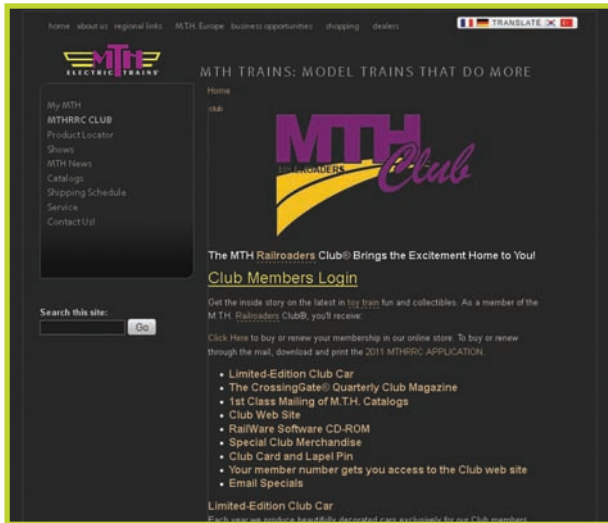

Not all products depicted in this catalog are production models. In some cases, the items pictured may be models in HO scale, O scale, or another scale that have been altered digitally. Each item's graphic features and content are subject to change after publication. All product features may be verified on their retail packages.

M.T.H. Electric Trains is in no way affiliated with any of the railroads featured in this catalog.

©2011, M.T.H. Electric Trains, 7020 Columbia Gateway Drive, Columbia Maryland 21046-1532 • www.mthtrains.com • 410-381-2580

MTH Trademarks: M.T.H. Electric Trains®, M.T.H.®, MTH Railroaders Club™, CrossingGate™, Ives®, Loco-Sound™, Proto-Sound® 2.0, Proto-Sound® 3.0, Proto-Speed Control™, Proto-Doppler™, Proto-Dispatch™, Proto-Cast™, ProtoSmoke™, Proto-Coupler™, Proto-Effects™, RailKing™, Rugged Rails®, RailKing One-Gauge™, RailTown™, Tinplate Traditions™, ScaleTrax™, RealTrax®, Z-750™, Z-4000®, Z-1000™, DCS™ and the MTH Numbering System and all others indicated throughout this catalog.

DCS™ Simply The Best Way To Run A Railroad™
M.T.H.'s DCS Digital Command System has received U.S. Patent No. 6,457,681. M.T.H.'s Proto-Sound® 2.0 system has received U.S. Patent

No's 6,457,681 B1 (sound system), 6,457,681 B1 (Proto-Speed Control™), 6,604,641 (Proto-Coupler™), 7,210,656 (Sound), 6,662,917 (Z/3Rail), 7,210,656 (Internet Downloads, Music & Doppler). 6,655,640 (Smoke Synchronization)
M.T.H.'s RealTrax® has received U.S. Patent No. 6,019,289.
M.T.H.'s Z-4000® Transformer has received U.S. Patent No's. 6,281,606 & 6,624,537.
HO Coupler 7,694,834

Kadee® is a registered Trademark of Kadee Quality Products Co.

Some images used in this publication © 2011 www.clipart.com

Lionel is a registered trademark of Lionel Trains LLC.
Lionel®, FasTrack™, TMCC, and TMCC-2 Legacy are registered trademarks of Lionel® Trains LLC.

Lionel Corporation Tinplate is licensed by Lionel® LLC

LENZ is a Trademark of Lenz Electronics GMBH.

RealTrax® layouts created with RR-Track™ which is a registered trademark of R&S Enterprises.

9 HOW CAN I LEARN MORE ABOUT DCS?

Follow the link to the protosound2.com Web site for DCS and Proto-Sound 2.0 information — and a list of Authorized DCS Demo Centers where you can try DCS hands-on.

HOW CAN I UPDATE MY DCS SYSTEM OR CHANGE A SOUND SET?

Only M.T.H. allows you to update your control system or change an engine's sound set right over the Internet. Follow the link to the protosound2.com Web site for DCS and Proto-Sound 2.0 downloads.



®/™ M&M'S, the letter M and the M&M'S Characters are registered trademarks of Mars, Incorporated and its affiliates.
©MARS, Incorporated 2011

© 2011 H-D, All Rights Reserved. Manufactured by M.T.H. Electric Trains under license from Harley-Davidson Motor Company.
© 2011 M.T.H. Electric Trains, 7020 Columbia Gateway Drive, Columbia, Maryland 21046

© 2011 Caterpillar
CAT, CATERPILLAR, their respective logos, "Caterpillar Yellow" and the "Power Edge" trade dress, as well as corporate and product identity used herein, are trademarks of Caterpillar and may not be used without permission.
www.cat.com
M.T.H. Electric Trains, a licensee of Caterpillar Inc.

"© 2011 Anheuser-Busch, Inc. All Rights Reserved."

Products bearing Chicago and North Western, Denver & Rio Grande, Denver & Rio Grande Western, MKT/Katy, Missouri Pacific, Southern Pacific, Union Pacific, Western Pacific are made under trademark license from Union Pacific Railroad Company.



...SIMPLY THE BEST WAY TO RUN A RAILROAD™

TRY IT at your local DCS Demo Center or learn more with a **Complimentary DVD** on DCS & M.T.H. technology.



FOLLOW US ONLINE



Take your favorite Proto-Sound 2.0 or 3.0 Locomotive to any Demo Center and experience the additional features your engine has with DCS Control.

WWW.MTHTRAINS.COM

