

# TINPLATE TRADITIONS<sup>®</sup>

By M.T.H. Electric Trains<sup>®</sup>

## TINPLATE TRADITIONS<sup>®</sup> Standard Gauge Switch Operating Instructions

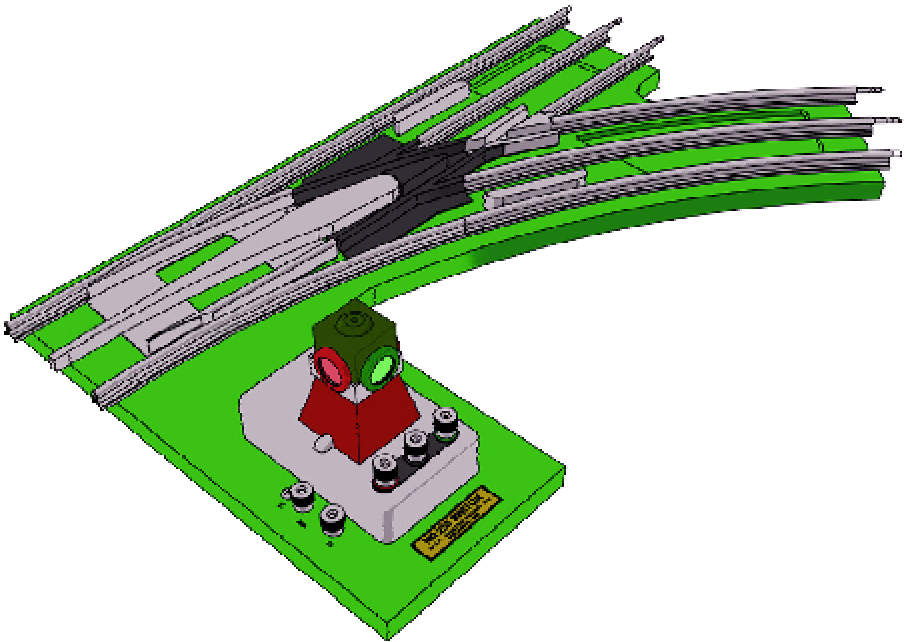

Thank you for purchasing the TINPLATE TRADITIONS<sup>®</sup> Standard Gauge Switch by M.T.H. Electric Trains<sup>®</sup>. Your new switch combines the designs and styles of yesteryear with the quality and craftsmanship of today's M.T.H. products to give you years of smooth and reliable operation.

# Switch Installation

## *Wiring Instructions*

Your new standard gauges switch can be wired into your layout using two basic configurations:

Configuration#1- Powering the operation of the switch using track power.

Configuration#2- Powering the operation of the switch using either a separate transformer or the auxiliary power output from your existing transformer.

Please refer to figures 1 and 2 below for wiring instructions for these two configurations.

---

### Configuration#1 Track Power Operation

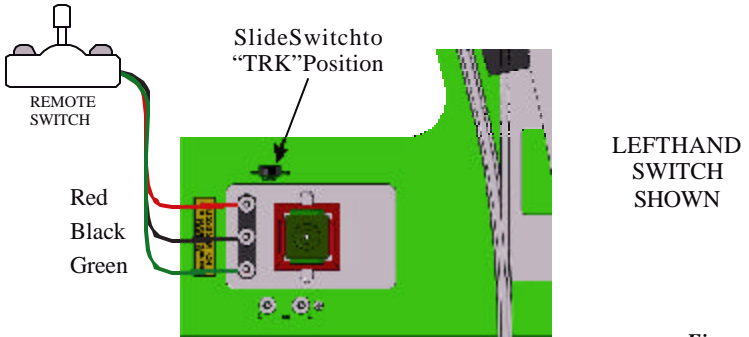

*Figure#1*

### Configuration#2 Auxiliary Power Operation

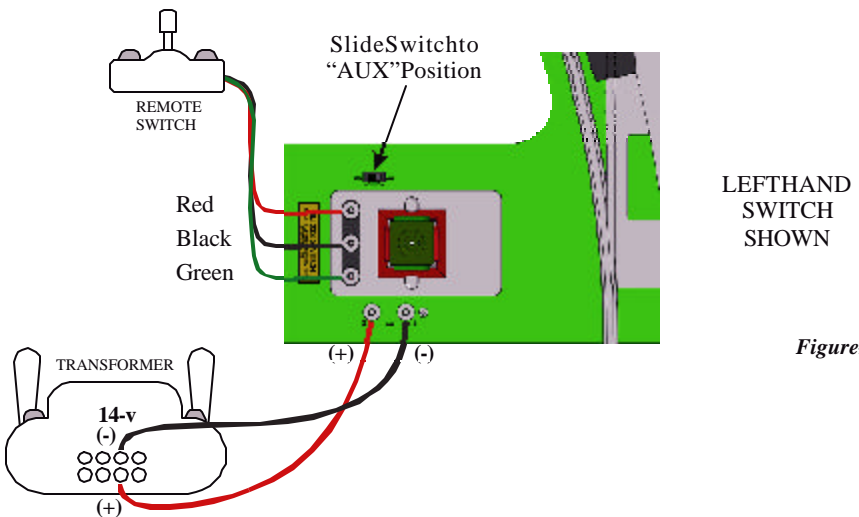

*Figure#2*

# Non-Derailing Feature

Your new standard gauge switch also includes a “non-derailing” feature. This feature will ensure that you will not have to worry about derailing trains through the switch. The non-derailing feature functions automatically to throw the switch even if the train is going to pass through the closed portion of the switch. Please refer to figures 3 and 4 for the proper location of the “Insulating Pins” before installing the switch into your layout. Please note that the proper installation of the “Insulating Pins” is essential to the operation of the “Non-derailing” feature. Please refer to figures 3 and 4 for explanations of “Open” and “Closed” switches.

## Closed Switch

Figure 3 - Showing correct signal indication when switch is closed so that the train continues down the straight track

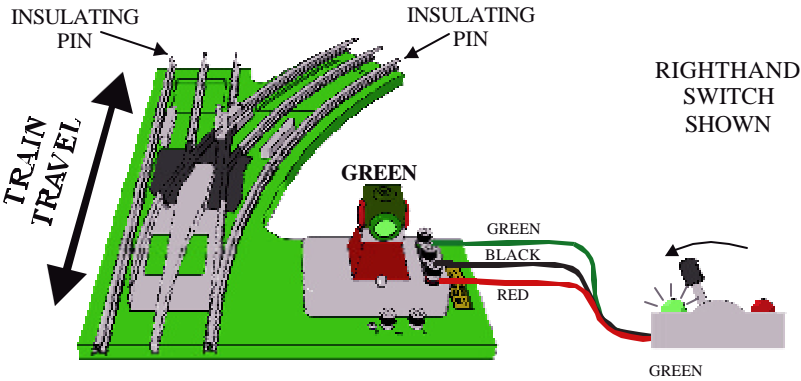

## Open Switch

Figure 4 - Showing correct signal indication when switch is open and the train is routed from the straight track into the curved track.

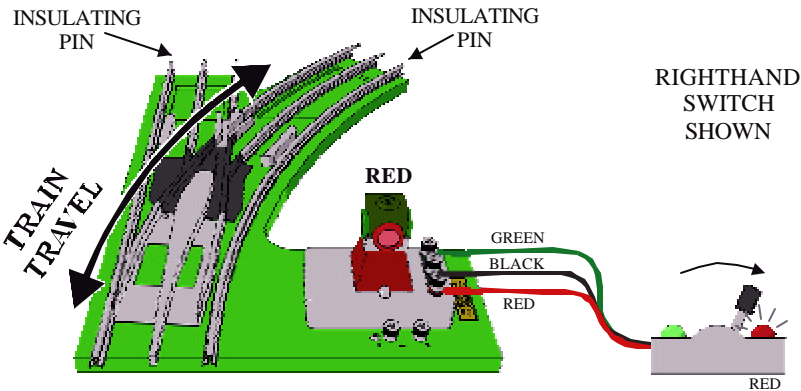

# Lamp Replacement

In the event that the lamps in either the switch lantern or remote switch burn out please refer to figures 5 and 6 for lamp replacement. Please call the M. T. H. Service Department (410-381-2580) for replacement lamps. (Part#CG-000017)

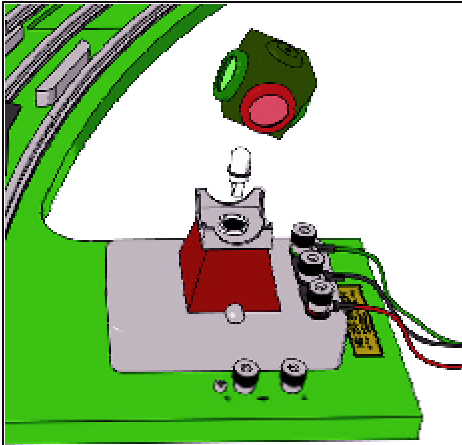

Figure#5-SwitchLantern

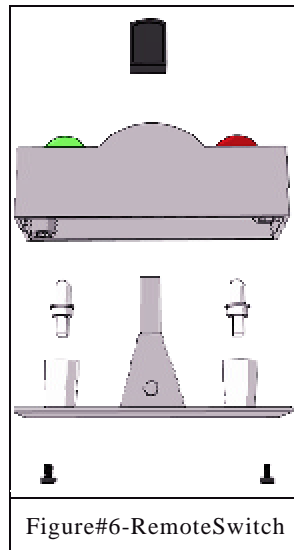

Figure#6-RemoteSwitch







## **SERVICE & WARRANTY INFORMATION**

### **HOW TO GET SERVICE UNDER THE TERMS OF THE LIMITED ONE YEAR WARRANTY**

For warranty repair, do not return your product to the place of purchase unless it was purchased from MTH Electric Trains in Columbia, MD. Instead, follow the instructions below to obtain warranty service as our dealer network is not prepared to service the product under the terms of this warranty.

- 1. First, write, call or FAX MTH Electric Trains, 7020 Columbia Gateway Dr., Columbia, MD 21046, 410-381-2580 (FAX No. 410-423-0009), or visit us on the Internet at [www.mth-railking.com](http://www.mth-railking.com) stating when it was purchased and what seems to be the problem. You will be given a return authorization number to assure that your merchandise will be properly handled upon its receipt.**
- 2. CAUTION: Make sure the product is packed in its original factory packaging including its foam and plastic wrapping material so as to prevent damage to the merchandise. The shipment must be prepaid and we recommend that it be insured. A cover letter, including your name, address, daytime phone number, Return Authorization number and a full description of the problem, a copy of your sales receipt, must be included to facilitate the repairs. Please include the description regardless of whether you discussed the problem with one of our service technicians when contacting MTH for your Return Authorization number.**
- 3. Please make sure you have followed the instructions carefully before returning any merchandise for service.**

### **LIMITED ONE YEAR WARRANTY**

This item is warranted for one year from the date of purchase against defects in material or workmanship. We will repair or replace (at our option) the defective part without charge for parts or labor, if the item is returned to the address below within one year of the original date of purchase. This warranty does not cover items that have been abused or damaged by careless handling. Transportation costs incurred by the customer are not covered under this warranty.

This warranty gives you specific legal rights and you may have other rights which vary from state to state.

ProtoSounds® is a trademark of MTH Electric Trains. DCRU® is a registered copyright of QS Industries, Inc. Lionel® and Railsound® are registered trademarks of Lionel L.L.C.