



SANTA FE STEEL RAIL FREIGHT HAULER 2-6-0 STEAM ENGINE TRAIN SET OPERATING INSTRUCTIONS



Making the Most of Your Investment

Thank you for purchasing this RailKing Ready-to-Run Steam Engine Train Set. We at MTH Electric Trains take pride in manufacturing quality products like your set, and we hope that you will enjoy it for a long time. To ensure the maximum durability and pleasure from locomotive, rolling stock, track and transformer, please read all the way through the **Quick Start Basic Operating Instructions** you will find on pages 4. Remember that a little attention to routine maintenance yields a maximum of trouble-free performance.

RAIL
KING

Table Of Contents

QUICK START - BASIC OPERATION(4
Setting Up The RiteTrax® Track System	4
Preparing The Locomotive & Cars For Operation	6
Lubrication	6
Operating The Locomotive & Cars	7
Electronic Reverse Unit	7
Transformer Operation	8
Special Reverse Unit Options	9
TRAIN SET MAINTENANCE	11
Oil	11
Grease	12
Locomotive Lamp Replacement	12
Passenger Car Lamp Replacement	13
Locomotive Traction Tire Replacement	15
RITETRAX® TRACK LAYOUT PLANS	16
TRANSFORMER COMPATIBILITY CHART	19
EXPLODED PARTS VIEW DIAGRAM	20
SAFETY & WARNING PRECAUTIONS	22
SERVICE AND WARRANTY INFORMATION	23
HOW TO GET SERVICE	23
LIMITED ONE YEAR WARRANTY	23

Compatibility

Our designers have sized the engine to operate on any traditional 0-27 or larger O Gauge track system, including RiteTrax using any standard AC transformer including the Z-500 transformer packaged in your set. (See page 19 for a complete list of compatible transformers as well as wiring instructions.) All RailKing products are compatible with most other 3-rail locomotives, rolling stock, and accessories.

Equipment Options

Your ready-to-run set features a 2-6-0 steam locomotive equipped with an operating headlight, mechanical whistle, ProtoSmoke® operating smoke unit and a solid state electronic reverse unit. All are simple and fun to operate. In addition to the locomotive, your set should also include a circle of RiteTrax® track (8 curved sections), a RiteTrax® lighted lock-on and wire harness set (for connecting the track to the transformer) and a 50-watt Z-500 transformer and controller.

You'll find complete instructions for choosing and setting up options in the following pages. If you don't read through the entire manual before starting to operate your equipment, be sure to check the **Quick Start Basic Operating Instructions**, which will give you the basics of the operating system.

CAUTION - ELECTRICALLY OPERATED PRODUCT:

Not recommended for children under ten years of age without adult supervision. As with all electric products, precautions should be observed during handling and use to reduce the risk of electric shock.

Transformer Ratings:

Input: 120 VAC
60 HZ Only
Output: 18VAC, 3A 54VA

Quick Start Operating Instructions

Track and Power

Although MTH Electric Trains manufactures its own track and transformers, you can run your locomotive on 0-27 or wider-radius O gauge track wired to draw power from any of the standard compatible AC transformers listed in the chart on page 19. Be sure your track is in good condition—clean and securely connected—to keep the locomotive running and to prevent derailments. If you intend to utilize the RiteTrax® track sections included in the set, see the directions below.

Setting Up the RiteTrax® Oval

Unlike other O Gauge track systems, each RiteTrax® track section features a realistic built-in roadbed base, solid nickel-silver track rails and realistic railroad ties all designed to give the owner an authentic looking track system. In addition, each RiteTrax® track section employs the use of quick-connect connectors instead of track pins or railjoiners to assemble the track sections to one another. The quick connectors and built-in base allow RiteTrax® track sections to be setup anywhere, including some carpeted surfaces without the need for track nails or the worry of carpet stains.



Figure 2: RiteTrax® sections in proper connected position.

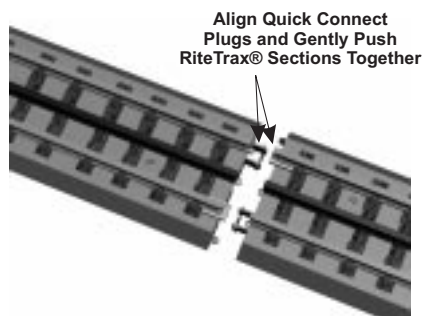

Figure 1: Preparing to snap RiteTrax® sections together by aligning Quick Connect Connectors together.

You can set up literally hundreds of different track designs utilizing RiteTrax® components. We've included just a few later in this manual for your reference. Each layout specifies the space required and the components needed to

complete the track design. You can purchase additional track components from any authorized MTH reseller.

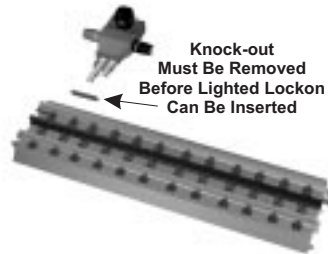

Figure 3: Top view position of lighted lockon preparing to enter RiteTrax® section.

transformer. Each RiteTrax® track section includes two “knock-out” tabs in the roadbed (on either end of the track) that must be removed

The lighted lockon included in your set snaps into any RiteTrax® track section roadbed and functions as the interface between the track and the

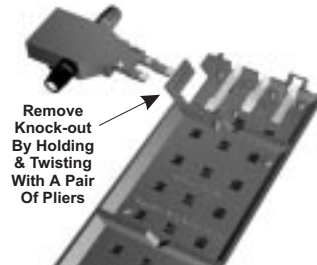

Figure 4: Underside view of RiteTrax® section with “knock-out” removed and lighted lockon in position for insertion.

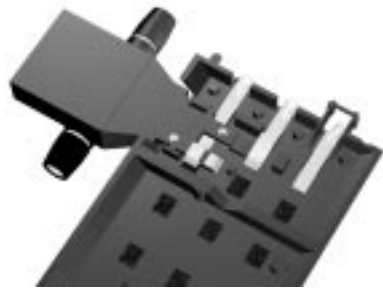

Figure 5: Underside view of RiteTrax® track section with lighted lockon in fully seated position.

to reveal the opening for the lighted lockon. To remove this *knock-out* grab the *knock-out* with a pair of pliers and gently twist the *knock-out* until it snaps away from the roadbed base. Once the *knock-out* has been removed, snap the lighted lockon into the roadbed taking care to make sure that the lockon arms snap into the roadbed electrical receptors. To complete the connection between the RiteTrax® track section and the transformer, simply plug in the color-coded wire harness that was included in your set.



Figure 6: Top view of RiteTrax® section with lighted lockon in fully seated position.

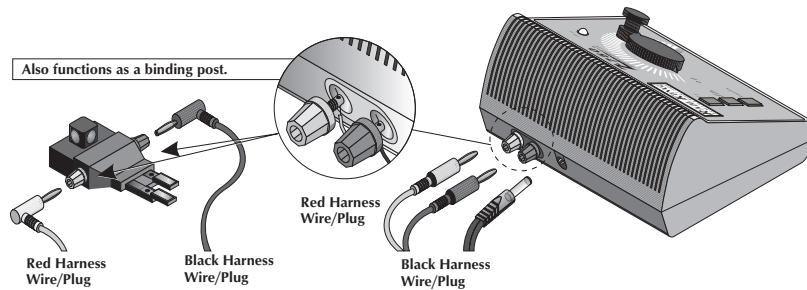

Figure 7: Wiring up the Z-500 transformer to the lighted locomotive.

Preparing the Locomotive & Cars For Operation

Before you run your locomotive, you **must** oil the locomotive.

Lubrication

Before you run the locomotive, use a light household or hobby oil to lubricate the gears and pickup rollers. Apply a small drop of oil (a pinpoint oiler will help place the right amount of oil where you need it) to each of the points indicated by in the diagram in figures 8. You may also want to use either a locomotive repair cradle or an old towel folded over to provide a protective bed for the locomotive shell while you're working on it.

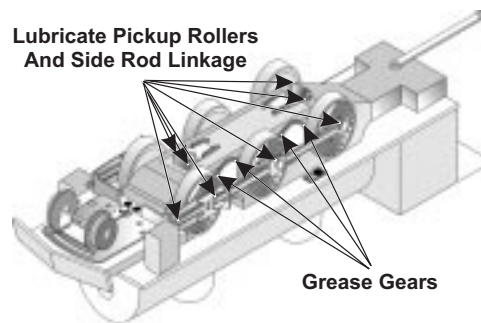

Figure 8: Lubrication points of RailKing 2-6-0 locomotive.

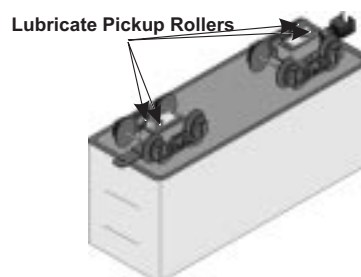

Figure 9: Lubricating The Tender.

Because the locomotives's internal gearing has been greased at the factory, you shouldn't need to add more grease until you have run the locomotive for 50 hours or owned it for a year, whichever comes first. See the section on lubrication, pages(s) 11-12, for detail.

Adding Smoke Fluid

The 2-6-0 contains a self-powered smoke unit that outputs a steady stream of smoke through the smoke stack on the roof of the engine. The ON/OFF switch located next to the trailing truck must be in the ON position in order for the smoke unit to function. See Fig. 10 below.

The smoke unit is essentially a small heating element and wick which soaks up and then "cooks" a mineral oil-based fluid that omits a harmless smoke. The smoke is then forced out of the stack via a small electric fan which runs at a constant speed. However, the smoke intensity can be varied by increasing the transformer voltage setting. The higher the setting, the more intense the smoke output

Before operating the engine, you should add smoke fluid to the smoke unit by pouring 15 - 25 drops of fluid into the locomotive's smoke stack. Use the included ProtoSmoke™ smoke fluid vial or Seuthe, LGB or LVTS smoke fluid before you run the engine. If you don't choose to add the fluid, then the smoke unit switch should be turned off. Failure to either add the fluid or turn the switch off could lead to damage to the smoke unit heating element and or wicking. Add the fluid through the smoke stack hole. After adding the fluid, gently blow into the stack to eliminate any air bubbles.

Do not overfill the unit as overfilling can cause the fluid to leak out and coat the interior engine components. When the smoke output begins to diminish while running the engine, an additional 10-15 drops of smoke fluid should be added or the smoke unit switch should be turned off.

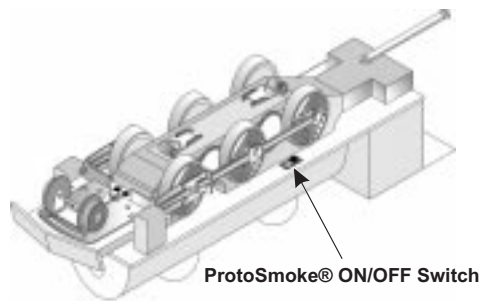

Figure 10: Locating the ProtoSmoke® ON/OFF Switch

When storing the engine for long periods of time, you may want to add at least 15 drops of fluid to keep the wick soaked with fluid and prevent it from drying out. After removing the engine from storage, it is advisable to add another 25 drops of fluid, letting the wick soak up the fluid for 15 minutes prior to operation.

Operating The Engine and Cars

Once the track has been assembled and the transformer wired to the track lock-on, you are almost ready to begin running your new train set.

Place the engine and cars on the track and couple each up to one another. If the coupler is already closed, pressing down on the coupler armature will open the coupler knuckle to allow the couplers to interlock with one another. Before turning on the transformer, it is important to understand the features of your new train set.

**Pushing Down
On The Coupler
Armature Opens
The Coupler
Knuckle**

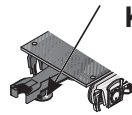

Figure 11: Pushing down on the coupler armature to open up the coupler knuckle.

Electronic Reverse Unit

The 2-6-0 model is controlled by an electronic reverse unit. The reverse unit operates in the same manner that all reverse units function by using forward, neutral and reverse states that are entered each time the throttle is turned on and off or by using the transformer direction switch (if so equipped).

In addition to the electronic reverse unit, your new train set locomotive features a mechanical whistle that can be activated by pressing the white Horn/Whistle button on your Z-500 transformer. Any compatible transformer whistle or horn button will also activate the horn in your new locomotive. Simply pressing the Horn/Whistle button whenever the throttle is above the OFF setting should activate the whistle. If the whistle doesn't blow, increase the throttle setting and press the button again. The whistle will blow as long as the button is depressed.

Now, **if you've lubricated the locomotive friction points as indicated earlier**, you're almost ready to start running your train set.

Transformer Operation

The Z-500 provides the model railroad enthusiast with an easy to use, safe power source for AC-powered trains and accessories. Set up is quick and easy by following the setup diagram below.

Functions:

Bell: Press to activate a digital sound system bell (not found on NYC 2-6-0 Steam Engine Set model number 68505340227), press again to deactivate.

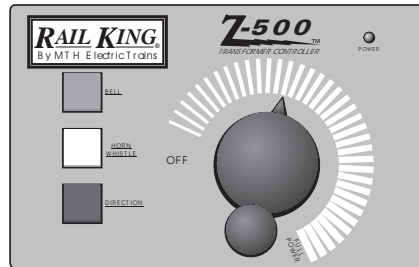

Figure 12: Z-500 Controls

Horn/Whistle: Press to activate.

Direction: Press to stop motion of train and press again to change direction

Starting to Roll

Advanced the transformer throttle. The locomotive's light will come on but the engine will not move until you turn the throttle back OFF and then ON again. The engine should now proceed in the forward direction. At this point, advancing the throttle further will allow the engine to pick up speed, reducing the throttle will slow the engine down. Turning the throttle OFF and then back ON will park the engine into neutral. Cycling the throttle OFF and then back ON again one more time will allow the locomotive to enter reverse.

An alternative method to using the throttle to enter the next reverse unit phase is to press the direction button. When depressed, the transformer interrupts all power to the track as long as the button is depressed. Releasing the button reapplies power to the track at whatever voltage level the transformer throttle is set at.

Press the horn button, the horn should sound.

Note: Pressing the bell button will have no affect on your engine because your locomotive is not equipped with a bell. Only locomotives equipped with full digital sound systems (which feature engine sounds, horns, bells, air-release sound effects, squeaking brakes and many other locomotive related sound effects) can utilize the bell button.

Special Reverse Unit Options

Locking Out The Reverse Unit Into One Full-Time Direction

Your electronic reverse unit locomotive may be locked out into one of three positions; forward, neutral or reverse. Locking the engine into one of these three positions prevents the locomotive from cycling through the reverse unit phases and is useful for operators employing block signal operations on their layout. Once locked into a position, turning the throttle off and then on again will not allow the engine to enter the next reverse unit phase and instead keeps the engine in the current locked out phase.

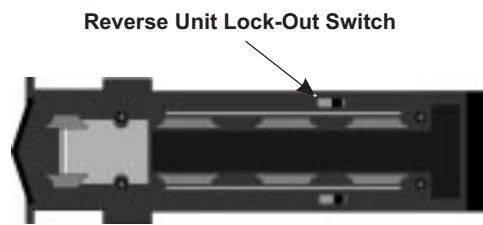

Figure 13: Electronic Reverse Unit Lock-out Switch location (bottom chassis view).

To lock out the engine into one of the three positions, simply enter that position using the transformer throttle or direction button. Once in the desired direction, remove the locomotive from the track and slide the ON/OFF switch located on the bottom of the chassis (See Figure 13) to the OFF position. This locks the engine into the desired direction. Sliding the switch back to the ON position resets the reverse unit into its normal reverse unit cycling phases.

Using the Z-500 With Self-Recharging, Battery Equipped After-Market Sound Systems

When using the Z-500 transformer with after-market digital sound systems employing a self-recharging battery backup system, operators should be aware MTH does not recommend leaving the engine in neutral with the power on and the throttle above the setting shown in Figure 10 for an extended period of time. If you are recharging the battery found in these after-market sound systems with a Z-500 transformer while in the neutral position, MTH recommends the throttle be positioned as shown in Figure 10 for optimum charging power.

Train Set Maintenance Instructions

Proper locomotive performance requires regular attention to lubrication. The following guidelines should be followed to ensure that your set's locomotive last for many years.

Oil

Before operating the locomotive, apply a small drop of oil to lubricate the side rods and pick up rollers. Use light household oil and apply

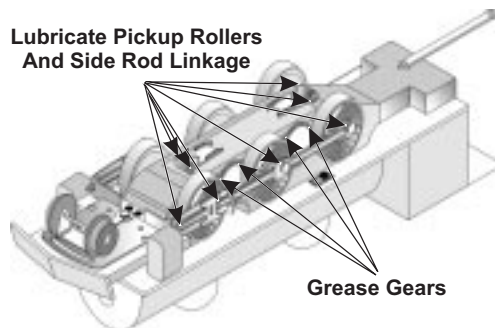

Figure 14: Removing the 2-6-0 locomotive shell from the chassis.

sparingly only to the points indicated by Figure 14. Wipe away any excess, especially if oil spills onto the finish of the locomotive. To prevent accidental scratches or other damage to the locomotive shell while you are working, you may want to place the locomotive in a repair cradle or an old towel or other cloth folded to provide a firm but soft resting place.

Check the locomotive oiling points periodically to be sure they are moving freely and quietly. If they are not, apply small amount of oil again. Also check locomotive wheels for dirt build up that can cause performance problems. Such dirt build up can interfere with electrical contacts, reduce traction (especially on elevated track sections), and cause neprene traction tires to wear out prematurely.

Grease

Grease may be added to the external drive gears in lieu of oil. To add grease simply apply liberally using a small screwdriver or toothpick to the gear teeth. Take care to rotate the gear by gently spinning the locomotive drive wheels so that all gear teeth can be greased.

Lamp Replacement

Your locomotive and caboose car may occasionally burn out their headlights and/or interior lights. Should this occur, you will need to remove the body from the chassis in order to replace the burned out bulb.

To remove the 2-6-0 locomotive cab from its chassis, follow the body removal instructions on the previous pages. Once the body has been removed, rotate the headlight bulb counter-clockwise as seen in Figure to remove the burned out bulb.



Figure 16: Locating and removing the light bulb.

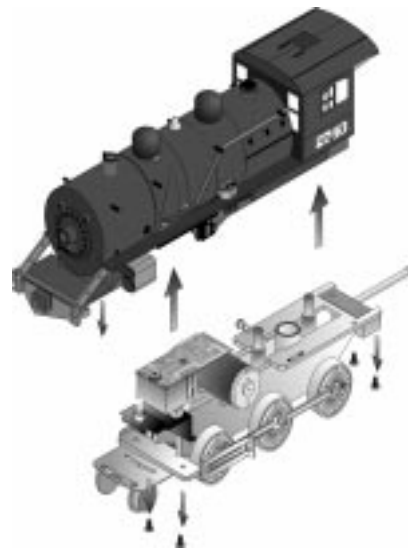

Figure 17: Removing the boiler to change the light bulb.

To remove the caboose car body from its chassis, turn the car over and locate and remove the four mounting screws (one in each corner of the car as seen in Figure 17) attaching the body to the chassis. Once the screws are removed, gently lift the car body up and away from the chassis.

After removing the body from the chassis, turn the chassis over and locate the two car interior lamp housings mounted on the inside of the chassis. Remove the burned out bulb by pushing the bulb downward and rotating it counter-clockwise as seen in Figure 18. Once the bulb has been removed, insert the replacement bulb by pushing down and turning the bulb clockwise to lock into place.



Figure 17: Removing the caboose body from its chassis.

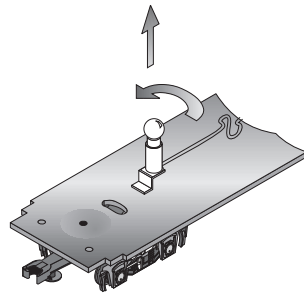
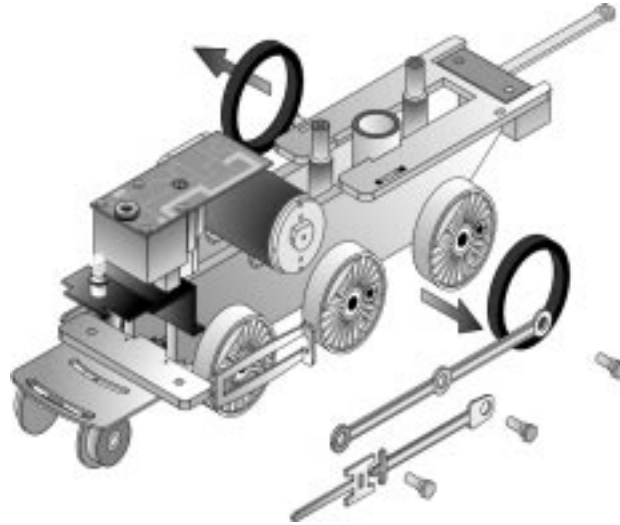

Figure 18: Locating and removing the interior bulbs.

Traction Tire Replacement Instructions

Your locomotive is equipped with two neoprene rubber traction tires (located on the rear drive wheels). While these tires are extremely

Figures 19: Changing the locomotive traction tires.



durable and long-lasting there may arise a time where they will need to be replaced. Should this occur, you will need to remove the locomotive side rods (the rods that connect each drive wheel to one another) in order to slip the new tire over the grooved drive wheel. The side rods are fastened to the drive wheels with a screw that can be removed with a 5mm nutdriver.

Before the new tire can be installed, you must make sure the old tire has been completely removed from the groove in the drive wheel. Use a razor blade or small flatblade screwdriver pry away any remains left from the old tire that may still be in the drive wheel groove. Once the old tire has been completely removed, slip the new tire onto the wheel. You may find it useful to use two small flatblade screwdrivers to assist you in stretching the tire over the wheel. Be careful to avoid twisting the tire when stretching it over the wheel. If a twist occurs, the tire will

have to be removed and reinstalled or a noticeable wobble in your engine will occur when operating the locomotive. In addition, it is important to make sure that the tire is fully seated inside the groove. Any portion of the tire extending out of the groove can cause the engine to wobble. A razor blade can be used to trim away any excess tire that doesn't seat itself inside the groove properly.

Replacement tires are available directly from MTH Electric Trains.

Locomotive Smoke Unit Maintenance

Operating the engine without smoke fluid and with the smoke unit switch in the ON position can damage your smoke unit wick, causing the wick to become hard, blackened and unabsorbant around the heating element. When this occurs, it may be difficult for the wick to soak up the smoke fluid resulting in poor or no smoke output. If that occurs, we recommend that

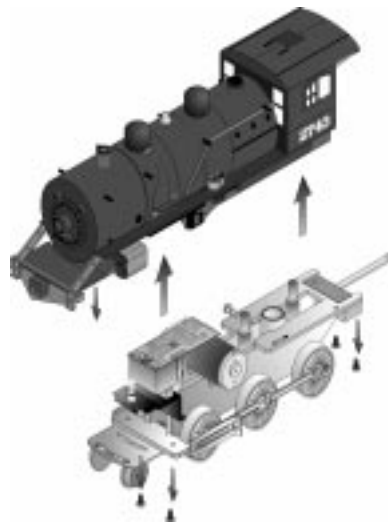

Figure 20: Removing the locomotive body for smoke unit maintenance.

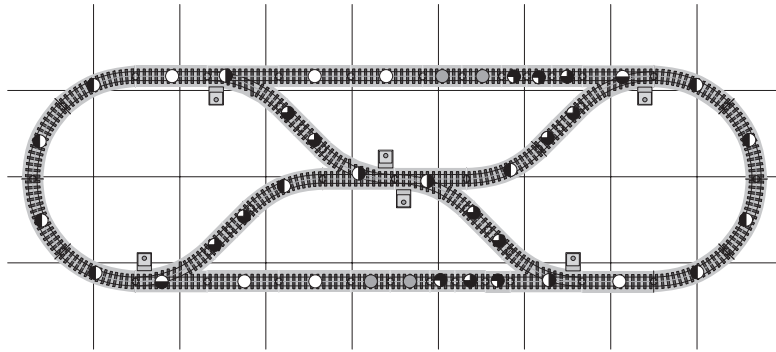

Figure 21: Opening the smoke unit for wick replacement.

you inspect and/or replace the wick taking care to not run the engine without fluid in the future. You can inspect the wick to see if it needs replacement by removing the smoke unit inspection cover from the body as seen in Fig. 21. After removing the chassis and inspection cover screws lift the inspection plate away and inspect the wick. If the wick is darkly discolored and hard, it should be replaced.

RiteTrax® Layout Plans

The following track plans are just some of the many different track plans you can utilize when designing your model railroad. Each track plan contains a table indicating which track components and how many you will need to purchase. Some track plans may require additional transformer power to accommodate the current draws of the various accessories featured in the layout, including switches and lights.



Track List:	Item #	Approximate Layout Size:
(6) ○ 10" Straight	(40-1001)	102' x 32' (2.6m x 0.8m)
(10) ● O-31 Curved	(40-1002)	
(4) ● O-31 Right Hand Switch	(40-1004)	
(2) ● O-31 Left Hand Switch	(40-1005)	
(4) ● 5.5" Straight	(40-1012)	
(10) ● 4.25" Straight	(40-1017)	
(4) ● 3.5" Straight	(40-1018)	

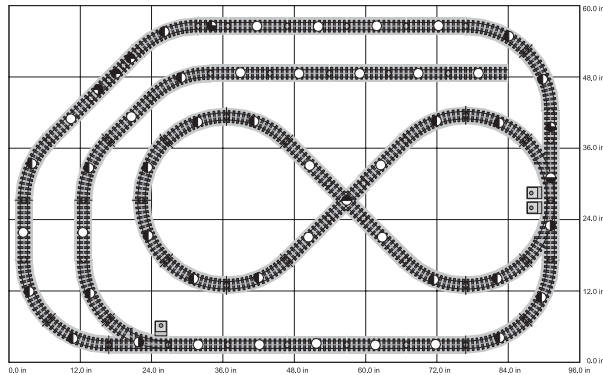

Track List:	Item #	Approximate Layout Size:
(22) ○ 10" Straight	(40-1001)	96' x 60' (2.4m x 1.5m)
(21) ● O-31 Curved	(40-1002)	
(2) ● O-31 Right Hand Switch	(40-1004)	
(1) ● O-31 Left Hand Switch	(40-1005)	
(1) ● 90 Degree Crossing	(40-1006)	
(2) ● 5.0" Straight	(40-1016)	
(1) ● 4.25" Straight	(40-1017)	
(2) ● 3.5" Straight	(40-1018)	

inXside.mt
size: 8.00 x 4.00
track sections: 52

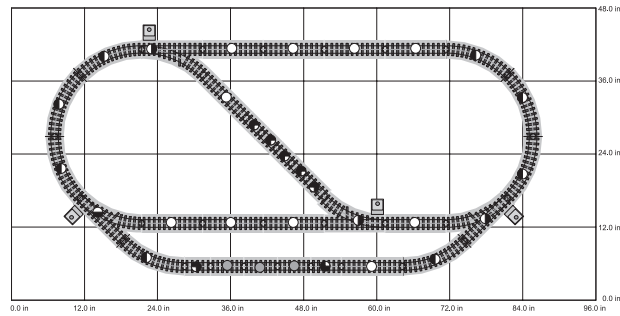

Intrepid31.rtr
size: 8.00 x 4.00
track sections: 32

Track List:	Item #
(10) 10" Straight	(40-1001)
(8) O-31 Curved	(40-1002)
(3) O-31 Right Hand Switch	(40-1004)
(1) O-31 Left Hand Switch	(40-1005)
(3) 5.5" Straight	(40-1012)
(1) 5.0" Straight	(40-1016)
(2) 4.25" Straight	(40-1017)
(4) 3.5" Straight	(40-1018)

Approximate Layout Size:
54" x 42" (2.1m x 1.1m)

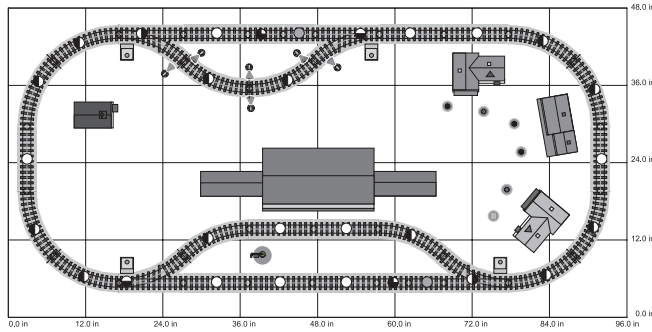

Intrepid5.rtr
size: 8.00 x 4.00
track sections: 30

Track List:	Item #
(10) 10" Straight	(40-1001)
(12) O-31 Curved	(40-1002)
(2) O-31 Right Hand Switch	(40-1004)
(2) O-31 Left Hand Switch	(40-1005)
(2) 5.5" Straight	(40-1012)
(2) 5.0" Straight	(40-1016)

Approximate Layout Size:
92" x 42" (2.3m x 1.1m)

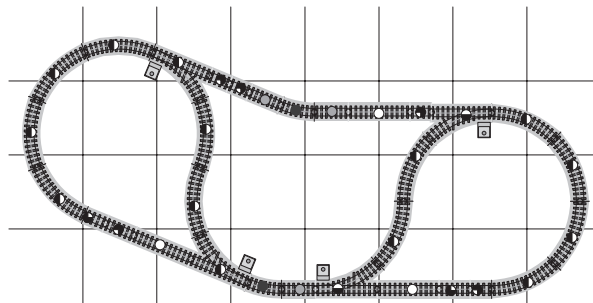

Track List:	Item #
(3) 10" Straight	(40-1001)
(12) O-31 Curved	(40-1002)
(2) O-31 Right Hand Switch	(40-1004)
(2) O-31 Left Hand Switch	(40-1005)
(3) 5.5" Straight	(40-1012)
(2) 5.0" Straight	(40-1016)
(5) 3.5" Straight	(40-1018)
(2) O-31 Half-Curved	(40-1022)

Approximate Layout Size:
96" x 48" (2.4m x 1.2m)

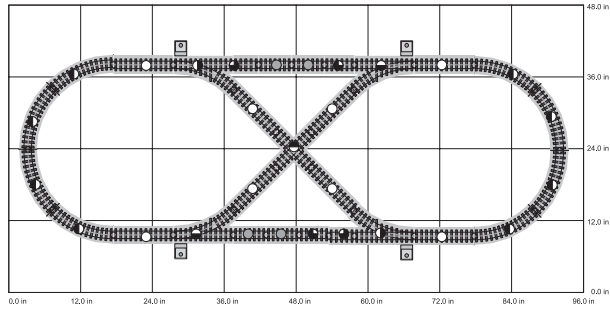

Track List:	Item #
(8) 10" Straight	(40-1001)
(8) O-31 Curved	(40-1002)
(2) O-31 Right Hand Switch	(40-1004)
(2) O-31 Left Hand Switch	(40-1005)
(1) 90 Degree Crossing	(40-1006)
(4) 5.5" Straight	(40-1012)
(2) 5.0" Straight	(40-1016)
(2) 4.25" Straight	(40-1017)

Approximate Layout Size:
92" x 36" (2.3m x 0.9m)

OvalKrt
size: 8.00 x 4.00
track sections: 37

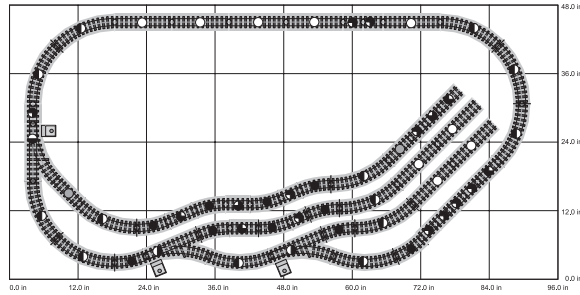

Track List:	Item #
(9) 10" Straight	(40-1001)
(13) O-31 Curved	(40-1002)
(2) O-31 Right Hand Switch	(40-1004)
(1) O-31 Left Hand Switch	(40-1005)
(2) 5.5" Straight	(40-1012)
(4) 5.0" Straight	(40-1016)
(2) 4.25" Straight	(40-1017)
(10) O-31 Half Curved	(40-1022)
(10) 3.5" Straight	(40-1018)

Approximate Layout Size:
90" x 48" (2.3m x 1.2m)

Scarve1.rst
size: 8.00 x 4.00
track sections: 53

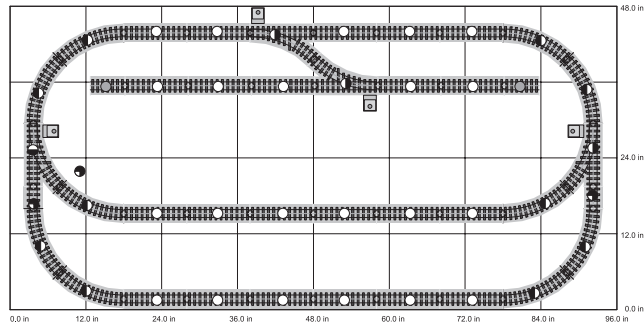

Track List:	Item #
(22) 10" Straight	(40-1001)
(10) O-31 Curved	(40-1002)
(3) O-31 Right Hand Switch	(40-1004)
(1) O-31 Left Hand Switch	(40-1005)
(2) 5.5" Straight	(40-1012)
(2) 3.5" Straight	(40-1018)

Approximate Layout Size:
96" x 48" (2.4m x 1.2m)

Siding.rst
size: 8.00 x 4.00
track sections: 40

TRANSFORMER COMPATIBILITY AND WIRING CHART

The 2-6-0 locomotive reverse unit is designed to work with any standard AC transformer. The chart below lists the many Lionel® compatible transformers, such as the Lionel KW or ZW models. In addition, the chart details how the terminals on these compatible transformers should be attached to your layout.

Transformer Model	Center Rail	Outside Rail	Min/Max. Voltage	Power Rating	Transformer Type
Lionel 1032	U	A	5-16v*	90-Watt	Standard**
Lionel 1032M	U	A	5-16v*	90-Watt	Standard**
Lionel 1033	U	A	5-16v*	90-Watt	Standard**
Lionel 1043	U	A	5-16v*	90-Watt	Standard**
Lionel 1043M	U	A	5-16v*	90-Watt	Standard**
Lionel 1044	U	A	5-16v*	90-Watt	Standard**
Lionel 1053	U	A	8-17v	60-Watt	Standard**
Lionel 1063	U	A	8-17v	60-Watt	Standard**
All-Trol	Left Terminal	Right Terminal	0-24v	300-Watt	Electronic ^{^A}
Cab-1/Powermaster	A	U	0-18v	135V. A.	Electronic ^A
Dallee Hostler	Left Terminal	Right Terminal			
Lionel LW	A	U	8-18v	75-Watt	Standard**
Lionel KW	A or B	U	6-20v	190-Watt	Standard**
MRC Tech II	Left Terminal	2 nd From Left	0-15v*	40V. A.	Electronic
Lionel MW	Outside Track Terminal	Inside Track Terminal	5-16v*	50V. A.	Electronic
R. O. W.	Red Terminal	Black Terminal	0-24v	384-Watt	Standard**
Lionel RS-1	Red Terminal	Black Terminal	0-18v	50V. A.	Electronic
Lionel RW	U	A	9-19v	110-Watt	Standard**
Lionel SW	U	A	Unknown	130-Watt	Standard**
Lionel TW	U	A	8-18v	175-Watt	Standard**
Lionel ZW	A, B, C or D	U	8-20v	275-Watt	Standard**
Lionel Trainmaster	Red Terminal	Black Terminal	0-18v	135-Watt	Electronic
MTH Z-500	Red Terminal	Black Terminal	0-18v	50-Watt	Electronic
MTH Z-500	Red Terminal	Black Terminal	0-21v	75-Watt	Electronic
MTH Z-4000	Red Terminal	Black Terminal	0-22v	400-Watt	Electronic

Exploded Parts View

The chart and diagram on the next several pages should be referenced when requesting replacement parts for your RailKing locomotive and cars. Parts can be ordered directly from MTH Electric Trains, 7020 Columbia Gateway Drive, Columbia, MD 21046-1532

RailKing - 2-6-0 Steam Locomotive w/mechanical whistle

Engine Parts

Name and Number	Part #
1.) Boiler (#2743)	FB-1200078
2.) Handrail (L)	FB-1220020
3.) Handrail (R)	FB-1210010
4.) Stanchion (Black)	FB-1200024
5.) Bell	FB-1200002
6.) Marker Light Lens (Green)	FA-1230021
7.) Head Light Lens	FA-1230022
8.) Screw (4.40 x 6.0mm)(roundhead)	IA-0000003
9.) Screw (6/32 x 6.0mm)(roundhead)	IA-0000027
10.) Bracket (Black metal)	IH-0000020
11.) DCRU	AC-0000003
12.) Smoke Unit	AA-1200013
13.) Bulb (18v, screw base)	CA-0230001
14.) Screw (M3 x 6.0mm)(roundhead)	IA-0000016
15.) Gear	EG-0000002
16.) Drive Block (3 axle)	DF-1200014
17.) Motor Mount	RI-0000011
18.) Motor (RS-280)	BE-0000023
19.)	
20.) Switch (Reverso lockout)	BB-0000006
21.) Traction Tires	DE-1050038
22.) Resistor	AI-0000005
23.) Switch (Smoke unit)	BB-1040002
24.) Drawbar (67.5mm long)(Blk)	FB-1200079
25.) Spring (5.5 x 11.0mm)	IE-0000007
26.) Screw (4.40 x 6.0mm)(washerhead)	IA-0000028
27.) Insulator (pickup)(bottom)(flat)	BD-0000024
28.) Pick up (8.0mm roller)(28.5mm long)	BD-0000038
29.) Screw (4.40 x 8.0mm)(chrome)(roundhead)	IA-0000029
30.) Crosshead	EC-1250010
31.) Side rod	EC-1250011
32.) Bolt (side rod)(chrome)(4.40 x 8.0mm w/ oversized shank)	IA-0000030
33.) Drive rod	EC-1250012
34.) Pivot plate (chrome)	IH-0000021
35.) Bolt (chrome)(4.40 x 8.0mm w/4.0mm oversized shank)	IA-0000030
36.) Screw (4.40 x 4.0mm)(roundhead)	IA-0000021
37.) Lead truck (single axle)	DA-1230013
38.) Pin (3.0 x 9.0mm)(single groove)	IG-0000007
39.) Spring (3.5 x 6.0 x 7.0mm)	IE-0000016
40.) Washer (3.1 x 6.7 x .4mm)	ID-0000028
41.) E-Clip (2.1 x 6.0 x .4mm)	IF-0000004
42.) Screw (4.40 x 6.0mm)(roundhead)	IA-0000003
43.) Screw (4.40 x 6.0mm)(roundhead)	IA-0000003
44.) Insulator (pick up)(top)	BD-0000026
45.) Nut	IC-0000005
46.) Screw (M2 x 4.0)(panhead)	IA-0000007
47.) Wick (smoke unit)	AA-0000001
48.) Screw (4.40 x 6.0mm)(roundhead)	IA-0000003
49.) Washer (4.8 x 9.0 x 2mm)(clear plastic)	ID-0000029

Tender Parts

Name and Number	Part #
1.) Tender Shell (NYC)	GA-1200031
2.) Motor Plate	BI-0000012
3.) Screw (M3 x 10.0mm)(Washerhead, self drilling)	IA-0000013
4.) Motor (FC-130)	BE-0000024
5.) Board (Whistle power)	AF-0000001
6.) Screw (4.40 x 6.0mm)(Roundhead)	IA-0000003
7.) Motor Mount	BI-0000013
8.) Screw (M3 x 10.0mm)(Washerhead, self drilling)	IA-0000013
9.) Whistle impellers (Plastic)	AI-0000006
10.) Whistle base	AI-0000007
11.) Floor (Tender)	GB-1200020
12.) Screw (M3 x 10.0mm)(Washerhead, self drilling)	IA-0000013
13.) Screw (M3 x 12.0mm)(Washerhead, self drilling)	IA-0000031
14.) Screw (4.40 x 6.0mm)(Roundhead)(Chrome)	IA-0000015
15.) Screw (4.40 x 6.0mm)(Roundhead)	IA-0000003
16.) Insulator (Pickup)(Top)	BD-0000026
17.) Truck	DA-1250007
18.) Nut (2.5 x 5.0 x 7.2mm)	IC-0000008
19.) Insulator (Pickup)(Bottom)(Flat)	BD-0000024
20.) Pickup (8.0mm roller)(23.5mm long)	BD-0000040
21.) Screw (4.40 x 6.0mm)(Roundhead)	IA-0000015
22.) T-Bar (4.0 x 20.0mm)	IG-0000001
23.) Coupler (51.0mm long)	DD-4000006
24.) Armature (45.0mm long)	DD-4000007
25.) Washer (clear)(5.0 x 9.0 x 0.2mm)	ID-0000031
26.) Washer	ID-0000000
27.) Spring (5.5 x 12.0mm)	IE-0000007
28.) E-Clip (3.4 x 8.0 x 0.6mm)	IF-0000002
29.) Screw (4.40 x 4.0mm)(Roundhead)	IA-0000021

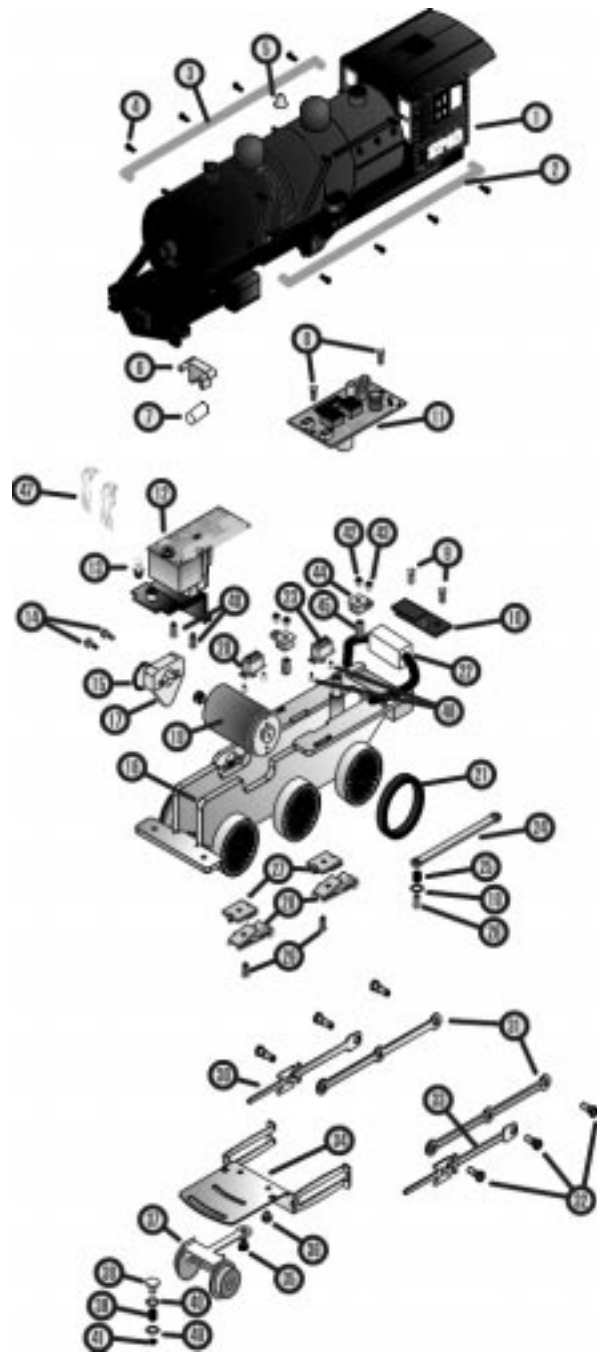

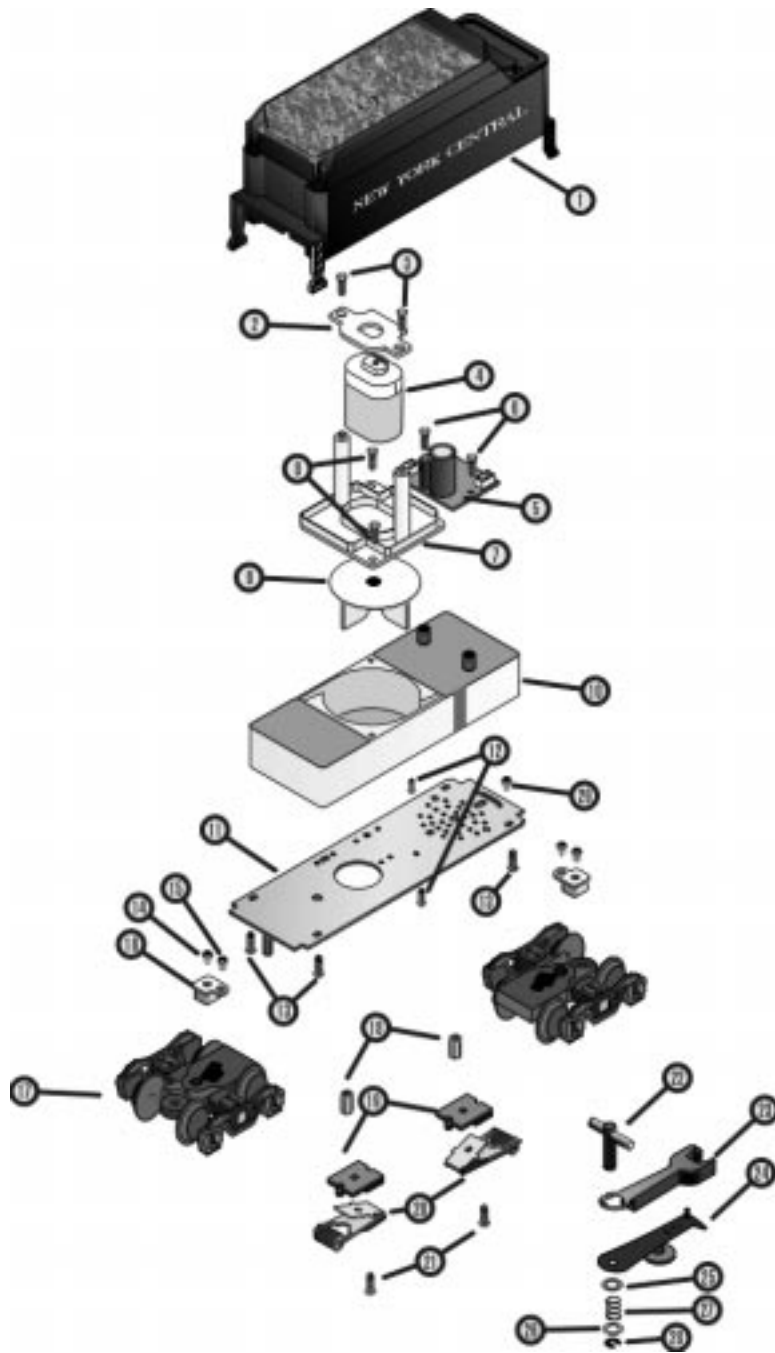

WARNING:

When using electrical products, basic safety precautions should be followed including the following:

Read this manual thoroughly before using this device. This device is not recommended for children under ten years of age without adult supervision.

MTH recommends parents examine the toy transformer periodically for conditions that may result in the risk of fire, electric shock, or injury to persons, such as damage to the primary or output cord, plug blades, housing or other parts, and that, in an event such conditions exist, the transformer should not be used until properly repaired.

This Z-500 Hobby Transformer Power Unit is intended to be used indoors. Do not use if water is present. Serious or fatal injury may result.

Do not use this Z-500 Hobby Transformer Power Unit for other than its intended purpose. This unit was designed to operate with Z-500 Control Unit.

This Z-500 Hobby Transformer Power Unit was designed to operate on 120 volt, 60 Hertz power. Do not connect to any other source of power.

Do not operate the Z-500 Hobby Transformer Power Unit with damaged cord, plug or case.

To avoid the risk of electrical shock, do not disassemble the unit. There are no user serviceable parts inside. If damaged call MTH service for instructions.

CAUTION: Do not operate your layout unattended. Obstructed accessories or stalled trains may overheat resulting in damage to your layout.

If the circuit breaker trips, unplug the power cord from power source (electrical wall outlet), check your layout for any short circuits, reset the circuit breaker, plug the power cord into the power source (electrical wall outlet), and resume operation. Unplug the Z-500 Hobby Transformer Power Unit from power source (electrical wall outlet) when not in use.

SERVICE AND WARRANTY INFORMATION

HOW TO GET SERVICE UNDER THE TERMS OF THE LIMITED ONE YEAR WARRANTY

For warranty repair, do not return your product to the place of purchase. Instead, follow the instructions below to obtain warranty service as our dealer network is not prepared to service the product under the terms of this warranty.

1. First, write, call or FAX MTH Electric Trains, 7020 Columbia Gateway Drive, Columbia, MD 21046, 410-381-2580 (FAX No. 410-381-6122), stating when it was purchased and what seems to be the problem. You will be given a return authorization number to assure that your merchandise will be properly handled upon its receipt.
2. CAUTION: Make sure the product is packed in its original factory packaging including its foam and plastic wrapping material so as to prevent damage to the merchandise. The shipment must be prepaid and we recommend that it be insured. *A cover letter, including your name, address, daytime phone number, a copy of your sales receipt, a Return Authorization number and a full description of the problem, must be included to facilitate the repairs. Please include the description regardless of whether you discussed the problem with one of our service technicians when contacting MTH for your Return Authorization number.*
3. Please make sure you have followed the instructions carefully before returning any merchandise for service.

LIMITED ONE YEAR WARRANTY

This item is warranted for one year from the date of purchase against defects in material or workmanship. We will repair or replace (at our option) the defective part without charge for parts or labor, if the item is returned to the address below within one year of the original date of purchase. This warranty does not cover items that have been abused or damaged by careless handling, traction tires or lamps. Transportation costs incurred by the customer are not covered under this warranty.

This warranty gives you specific legal rights and you may have other rights which vary from state to state.

Proto-Sound® is a trademark of MTH Electric Trains. DCRU® is a registered copyright of QS Industries, Inc.